



## COMPETENCE, QUALITY AND SPECIALIZATION.

Production, quality, range and specialization: on these strengths PG has founded its own production and organizational structure.

The reliability of the PG brand grows and strengthens throughout its history: born in the 1950s as a precision mechanical workshop specializing in the manufacture of metal parts in the early 1980s, while continuing its original business, PG's production and sales started with other products, expanding and diversifying the range of tools and drill accessories.

A long experience and an innovative and dynamic reality that always ensures precise and specific responses, have enabled PG to identify and develop new projects, select and qualify raw materials, online controls and on finished products, optimizing operating times, rational and safe management methods, scrupulous approval tests and strict controls in accordance with current European safety standards, to reach an accurate packaging study for the best lay-out at the point of sale. All this trying to reduce as much as possible the environmental impact during the manufacturing cycle, in a secure, responsible and collaborative work environment.





## EXPERIENCE, FLEXIBILITY AND UNIVERSALITY.

PG has developed and strengthened a capillary, efficient and flexible distribution network on the most important Italian and foreign markets, enabling customers to have a constant availability of a dialogue, an high level of service and a great relationship between price and quality.

PG range is constantly evolving and is able to provide a complete and compatible assortment with the most important brands of power tools. These are the features and benefits that make PG a guarantee and a landmark for those who want the best of production in the DIY, hardware and tools market.

The experience matured by PG, working daily with its customers, has enabled it to develop a deep knowledge of the exhibition and logistics needs of the point of sale.

A careful study of packaging, its colors and the harmonization of its formats, has been combined with the search for modular and flexible solutions for exposure. PG is able to offer a particularly effective display system, which allows to show the full range of products with a strong visual impact for customers.

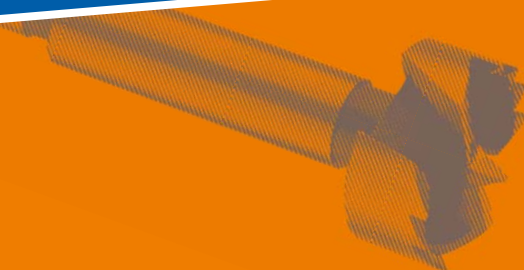

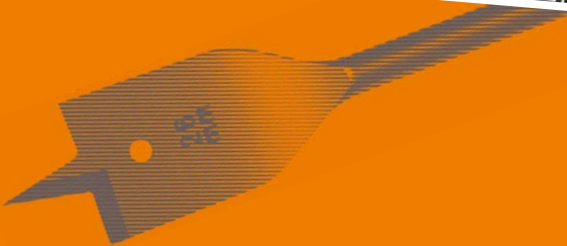
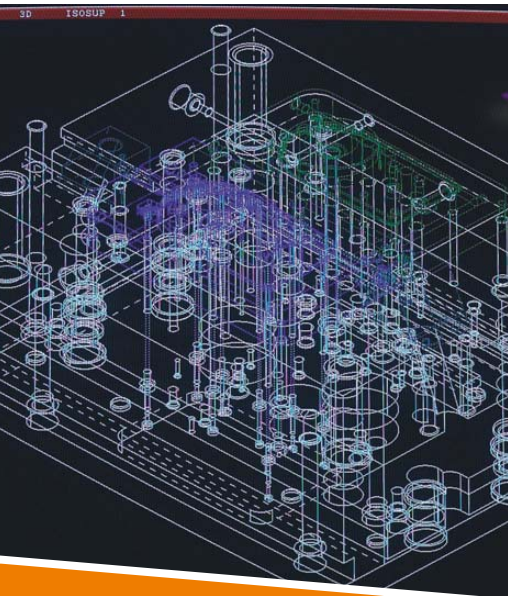
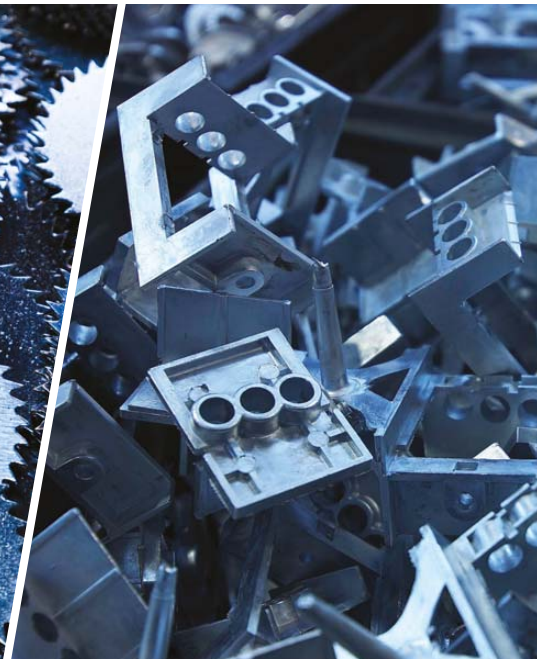



## YOUR PROFESSIONAL PARTNERS

A full range of selected accessories and tools for the DIY compatible with all major brands of power tools and able to respond with confidence and reliability to all the needs in the market of DIY, hardware and tools.



**Professional**



1 x 2 m



2 x 2 m

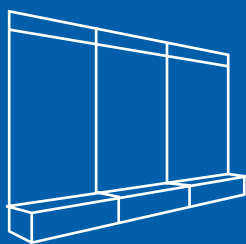

3 x 2 m



## MINI SIZE, BIG PRECISION

An extensive line of mini tools and accessories for modelling, hobby, electronics and craft, which combines the precision and resistance to the force of universality, with a modern and attractive packaging for a strong visual impact.







## SPORT

PG has been firmly linked to the sporting tradition of its city for years now, a lasting bond dictated by the passion and value that sport occupies in life. We are Business Partner of Bologna FC 1909 and Official Sponsor of Virtus basketball.





10



PLUMBING

12



HSS TOOLS

14



UNIVERSAL ACCESSORIES

43



RASPING

45



BITS

48



BRUSHING

58



HEALTH AND SAFETY

68



WOOD JOINTING

70



JIGSAW BLADES

73



HOLE SAWS

75



CIRCULAR SAWS



92



CARVING ENGRAVING MILLING

95

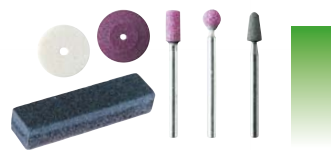

GRINDING SHARPENING

98



SANDING

106



ACCESSORIES

112



TOOLS TRANSFORMERS KITS

16



POLISHING

19



SANDING

31



CUTTING  
GRINDING

39



MILLING

41



FLAT DRILLS  
& FORSTNER BITS

61



MIXING

62



CUTTERS

64



WOOD TOOLS

66



STAPLING

67



MEASURING

76



CHUCKS

79



TOOLS AND  
ACCESSORIES

81



CLAMPING

84



DRILL STANDS

86



DRILLING

100



CLEANING POLISHING

103



CUTTING ROUGHING

105



HSS DRILL BITS

**TAP RE-SEATING TOOL**

For taps with external thread

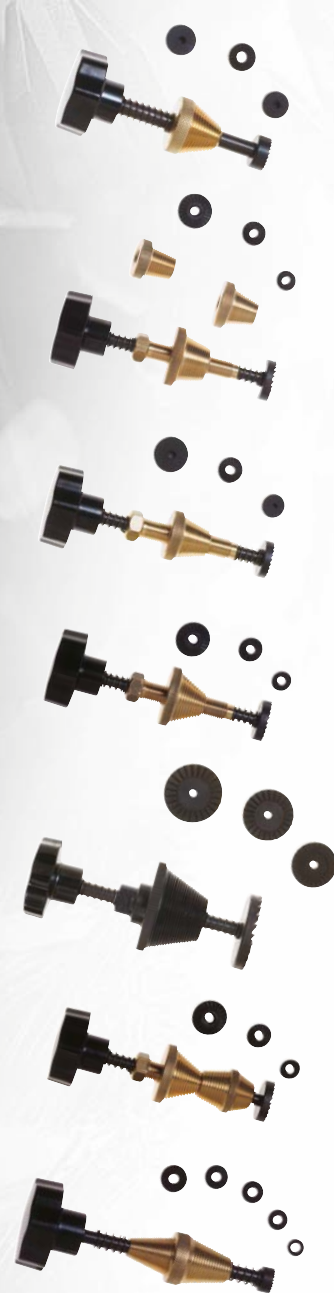

<b>103</b>	with conical part $\varnothing$ <b>28 x 25</b> mm and cutter <b>1/2</b>	10	103006
<b>212</b>	with conical part $\varnothing$ <b>28 x 25</b> mm <b>2</b> cutters <b>3/8 - 1/2</b> and <b>2</b> washers	10	212005
<b>201</b>	with conical part $\varnothing$ <b>40 x 27</b> mm <b>4</b> cutters <b>3/8 - 1/2 - 3/4 - 1"</b> <b>2</b> conical spare parts $\varnothing$ <b>27 - 32</b> mm	1	201009
<b>203</b>	with conical part $\varnothing$ <b>32 x 27</b> mm <b>2</b> cutters <b>1/2 - 3/4</b> and <b>2</b> washers	1	203003
<b>205</b>	with conical part $\varnothing$ <b>40 x 27</b> mm <b>4</b> cutters <b>3/8 - 1/2 - 3/4 - 1"</b>	1	205007
<b>204</b>	with conical part $\varnothing$ <b>65 x 65</b> mm <b>4</b> cutters <b>1" 1/8 - 1" 1/4 - 1" 1/2 - 2"</b>	1	204147
<b>207</b>	with conical part $\varnothing$ <b>40 x 27</b> mm <b>4</b> cutters <b>3/8 - 1/2 - 3/4 - 1"</b>	1	207001
<b>208</b>	with double conical part $\varnothing$ <b>30 x 60</b> mm <b>6</b> cutters $\varnothing$ <b>10 - 12 - 13 - 14 - 15 - 16</b> mm	1	208008
<b>209</b>	with double conical part $\varnothing$ <b>25 x 46</b> mm <b>3</b> cutters $\varnothing$ <b>13 - 15 - 16</b> mm	1	209005

**TAP RE-SEATING TOOL**

For taps with external-internal thread



<b>202</b>	with conical part $\varnothing$ <b>42 x 42</b> mm <b>4</b> cutters <b>3/8 - 1/2 - 3/4 - 1"</b>	1	202006
------------	---	---	--------

**TAP RE-SEATING TOOL**

For taps with external-cylindrical thread

<b>210</b>	with cylindrical part $\varnothing$ <b>33 x 38</b> mm <b>4</b> cutters <b>3/8 - 1/2 - 3/4 - 1"</b>	1	210001
<b>213</b>	with cylindrical part $\varnothing$ <b>28 x 24</b> mm <b>2</b> cutters <b>3/8 - 1/2</b> and <b>2</b> washers	10	213002

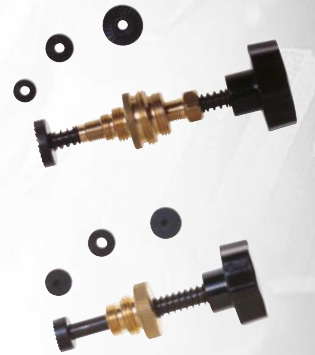
**CUTTER**

<b>11.010</b>	$\varnothing$ <b>10</b> mm	10	110103
<b>11.012</b>	$\varnothing$ <b>12</b> mm	10	110127
<b>11.014</b>	$\varnothing$ <b>14</b> mm - <b>3/8</b>	10	110141
<b>11.017</b>	$\varnothing$ <b>17</b> mm - <b>1/2</b>	10	110172
<b>11.024</b>	$\varnothing$ <b>24</b> mm - <b>3/4</b>	10	110240
<b>11.028</b>	$\varnothing$ <b>28</b> mm - <b>1"</b>	10	110288
<b>11.034</b>	$\varnothing$ <b>34</b> mm - <b>1" 1/8</b>	5	110349
<b>11.038</b>	$\varnothing$ <b>38</b> mm - <b>1" 1/4</b>	5	110387
<b>11.043</b>	$\varnothing$ <b>43</b> mm - <b>1" 1/2</b>	5	110431
<b>11.055</b>	$\varnothing$ <b>55</b> mm - <b>2"</b>	5	110554

**PIPE CUTTER**

For pipes of copper, brass, plastic, iron

<b>316.00</b>	from <b>1/8</b> to <b>5/8</b> - <b>16</b> mm	5	316000
---------------	--	---	--------

**SPARE CUTTING BLADE**

<b>333.00</b>	universal	10	333007
---------------	-----------	----	--------

**UNIVERSAL WRENCH**

<b>305.00</b>	can be used on left-hand or right-hand nuts	5	305004
---------------	---	---	--------



**HSS ENLARGING CUTTER for steel**

<b>800.00</b>	from $\varnothing$ <b>3</b> mm to $\varnothing$ <b>14</b> mm - shank $\varnothing$ <b>6</b> mm - <b>550</b> RPM	1	800004
<b>805.00</b>	from $\varnothing$ <b>6</b> mm to $\varnothing$ <b>20</b> mm - shank $\varnothing$ <b>8</b> mm - <b>500</b> RPM	1	805009
<b>810.00</b>	from $\varnothing$ <b>8</b> mm to $\varnothing$ <b>30</b> mm - shank $\varnothing$ <b>10</b> mm - <b>400</b> RPM	1	810003
<b>820.00</b>	from $\varnothing$ <b>20</b> mm to $\varnothing$ <b>40</b> mm - shank $\varnothing$ <b>10</b> mm - <b>300</b> RPM	1	820002
<b>825.00</b>	from $\varnothing$ <b>20</b> mm to $\varnothing$ <b>50</b> mm - shank $\varnothing$ <b>10</b> mm - <b>200</b> RPM	1	825007

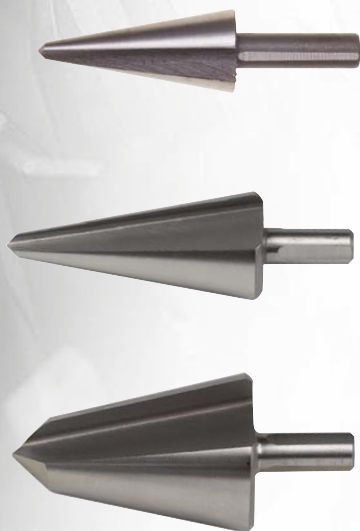

**HSS STEP DRILL BIT for steel**

<b>825.50</b>	from $\varnothing$ <b>4</b> mm to $\varnothing$ <b>12</b> mm - shank $\varnothing$ <b>6</b> mm - <b>800</b> RPM	1	825502
<b>826.00</b>	from $\varnothing$ <b>4</b> mm to $\varnothing$ <b>20</b> mm - shank $\varnothing$ <b>8</b> mm - <b>500</b> RPM	1	826004
<b>828.00</b>	from $\varnothing$ <b>4</b> mm to $\varnothing$ <b>30</b> mm - shank $\varnothing$ <b>10</b> mm - <b>400</b> RPM	1	828008
<b>829.00</b>	from $\varnothing$ <b>3,5</b> mm to $\varnothing$ <b>40</b> mm - shank $\varnothing$ <b>10</b> mm - <b>300</b> RPM	1	829005



**HSS ENLARGING CUTTER** for steel

<b>835.00</b>	from $\varnothing$ <b>0</b> mm to $\varnothing$ <b>25</b> mm - shank $\varnothing$ <b>8</b> mm - <b>500</b> RPM	5	835006
<b>835.50</b>	from $\varnothing$ <b>6</b> mm to $\varnothing$ <b>32</b> mm - shank $\varnothing$ <b>10</b> mm - <b>500</b> RPM	1	835501
<b>835.60</b>	from $\varnothing$ <b>6</b> mm to $\varnothing$ <b>45</b> mm - shank $\varnothing$ <b>10</b> mm - <b>300</b> RPM	1	835600

**HSS COUNTERSINK** for steel - shank  $\varnothing$  **8** mm

<b>840.00</b>	$\varnothing$ <b>12</b> mm - <b>500</b> RPM	5	840000
<b>845.00</b>	$\varnothing$ <b>16</b> mm - <b>500</b> RPM	5	845005
<b>850.00</b>	$\varnothing$ <b>20</b> mm - <b>500</b> RPM	5	850009

**ADJUSTABLE HOLE CUTTER** for cutting laminates, metal

<b>214.00</b>	with $\varnothing$ <b>6</b> mm HSS drill - for holes from <b>20</b> mm to <b>123</b> mm <b>250</b> RPM	5	214009
<b>215.00</b>	with $\varnothing$ <b>10</b> mm HSS drill - for holes from <b>25</b> mm to <b>217</b> mm <b>250</b> RPM	5	215006
<b>216.00</b>	with $\varnothing$ <b>4</b> mm HSS drill - for holes from <b>27</b> mm to <b>104</b> mm <b>250</b> RPM	5	216003

**HSS CUTTING TOOL**

<b>214.10</b>	$\square$ <b>5</b> mm for art. <b>214.00</b>	5	214108
<b>215.10</b>	$\square$ <b>6</b> mm for art. <b>215.00</b>	5	215105
<b>216.10</b>	$\varnothing$ <b>5</b> mm for art. <b>216.00</b>	5	216102



**CONE-SHAPED STEEL RING NUT - collar ø 22 mm**

<b>218.00</b>	<b>14 MA</b>	<input checked="" type="checkbox"/>	218007
<b>220.00</b>	<b>8 MA</b>	<input type="checkbox"/>	220000
<b>220.50</b>	<b>10 MA - collar ø 16 mm</b>	<input type="checkbox"/>	220505
<b>221.00</b>	<b>10 MA</b>	<input type="checkbox"/>	221007
<b>222.00</b>	<b>14 MA</b>	<input type="checkbox"/>	222004
<b>223.00</b>	<b>5/8"</b>	<input type="checkbox"/>	223001

**FLAT STEEL RING NUT - collar ø 22 mm**

<b>219.00</b>	<b>14 MA</b>	<input checked="" type="checkbox"/>	219004
<b>224.00</b>	<b>8 MA</b>	<input type="checkbox"/>	224008
<b>225.00</b>	<b>10 MA</b>	<input type="checkbox"/>	225005
<b>226.00</b>	<b>14 MA</b>	<input type="checkbox"/>	226002
<b>227.00</b>	<b>5/8"</b>	<input type="checkbox"/>	227009

**STEEL UNIVERSAL WRENCH for ring nuts**

<b>228.00</b>	<b>35 mm</b>	<input checked="" type="checkbox"/>	228006
<b>229.00</b>	<b>35 mm</b>	<input type="checkbox"/>	229003
<b>230.00</b>	<b>20/35 mm - adjustable</b>	<input checked="" type="checkbox"/>	230009
<b>231.00</b>	<b>20/35 mm - adjustable</b>	<input type="checkbox"/>	231006

**ARBOR**

<b>335.00</b>	<b>10,0 x 6 mm</b>	<input checked="" type="checkbox"/>	335001
<b>336.00</b>	<b>12,8 x 8 mm</b>	<input checked="" type="checkbox"/>	336008
<b>337.00</b>	<b>22,2 x 8 mm</b>	<input type="checkbox"/>	337005

**STEEL BACK NUT**

<b>250.00</b>	for discs ø <b>115 mm</b> ø <b>41 mm</b> - thickness <b>7,5 mm</b> - hole ø <b>14 mm</b>	<input type="checkbox"/>	250007
<b>253.00</b>	for discs ø <b>230 mm</b> ø <b>41 mm</b> - thickness <b>9 mm</b> - hole ø <b>14 mm</b>	<input type="checkbox"/>	253008



ref.

description

pack  
q.tyEAN13  
8011017**UNIVERSAL  
ACCESSORIES****RUBBER BACKING PAD**

<b>338.00</b>	ø <b>125</b> mm - gambo ø <b>6</b> mm	10	338002
<b>338.05</b>	ø <b>180</b> mm - bore ø <b>16</b> mm	10	338057
<b>338.08</b>	ø <b>180</b> mm - bore ø <b>16</b> mm	10	338088

**NYLON BACKING PAD**

<b>338.10</b>	ø <b>100</b> mm - bore ø <b>10</b> mm	10	338101
<b>338.20</b>	ø <b>115</b> mm - bore ø <b>14</b> mm	10	338200
<b>338.22</b>	ø <b>178</b> mm - bore ø <b>14</b> mm	10	338224
<b>338.25</b>	ø <b>100</b> mm - bore ø <b>10</b> mm	10	338255
<b>338.30</b>	ø <b>115</b> mm - bore ø <b>10</b> mm	10	338309
<b>338.35</b>	ø <b>115</b> mm - bore ø <b>14</b> mm	10	338354
<b>338.40</b>	ø <b>115</b> mm - bore ø <b>16</b> mm	10	338408
<b>338.45</b>	ø <b>125</b> mm - bore ø <b>14</b> mm	10	338453
<b>338.50</b>	ø <b>125</b> mm - bore ø <b>16</b> mm	10	338507
<b>338.55</b>	ø <b>150</b> mm - bore ø <b>14</b> mm	10	338552
<b>338.60</b>	ø <b>150</b> mm - bore ø <b>16</b> mm	10	338606
<b>338.65</b>	ø <b>178</b> mm - bore ø <b>14</b> mm	10	338651
<b>338.70</b>	ø <b>178</b> mm - bore ø <b>16</b> mm	10	338705

**VELCRO BACKING PAD**shank ø **10** mm - bore **M14**

<b>338.80</b>	ø <b>115</b> mm	5	338804
<b>338.82</b>	ø <b>125</b> mm	5	338828
<b>338.85</b>	ø <b>150</b> mm	5	338859



PG pack

neutral pack

**BUFFING BONNET WITH TIGHTENING**

<b>339.00</b>	∅ 140 mm	10	339009
<b>339.20</b>	∅ 190 mm	10	339207

**LAMBSWOOL BONNET VELCRO FITTING**

<b>339.22</b>	∅ 115 mm	10	339221
<b>339.23</b>	∅ 125 mm	10	339238
<b>339.24</b>	∅ 160 mm	10	339245

**FELT BUFFING WHEEL**

<b>339.25</b>	∅ 80 x 10 mm - hole ∅ 13 mm	10	339252
<b>339.27</b>	∅ 125 x 15 mm - hole ∅ 16 mm	10	339276
<b>339.28</b>	∅ 150 x 20 mm - hole ∅ 16 mm	10	339283

**FELT POLISHING DISC VELCRO FITTING**

<b>339.26</b>	∅ 125 mm	10	339269
---------------	----------	----	--------

**FELT POLISHING PAD VELCRO FITTING**

<b>339.29</b>	93 mm	10	339290
---------------	-------	----	--------

**COTTON BUFFING WHEEL**

<b>339.30</b>	∅ 80 mm - shank ∅ 6 mm	10	339306
<b>339.35</b>	∅ 100 mm - hole ∅ 20/13 mm	10	339351
<b>339.40</b>	∅ 120 mm - hole ∅ 20/16 mm	10	339405
<b>339.45</b>	∅ 150 mm - hole ∅ 20/16 mm	10	339450

ref.

description

pack  
q.tyEAN13  
8011017**POLISHING****COTTON AND SISAL POLISHING WHEEL**

<b>339.46</b>	∅ <b>80</b> mm - shank ∅ <b>6</b> mm	10	339467
<b>339.49</b>	∅ <b>150</b> mm - hole ∅ <b>20/16</b> mm	10	339498

**POLISHING CUSHION**

<b>339.50</b>	∅ <b>125</b> mm - shank ∅ <b>6</b> mm	1	339504
<b>339.60</b>	∅ <b>175</b> mm - bore <b>M14</b>	1	339603

**POLISHING CUSHION PAD**

<b>339.62</b>	∅ <b>125</b> mm	1	339627
<b>339.64</b>	∅ <b>175</b> mm	1	339641

**POLISHING CUSHION PAD VELCRO FITTING**

<b>339.66</b>	∅ <b>115</b> mm	1	339665
<b>339.67</b>	∅ <b>125</b> mm	1	339672
<b>339.68</b>	∅ <b>160</b> mm	1	339689

**POLISHING PASTE**

<b>359.36</b>	<b>2</b> pre-polishing pastes	10	359366
<b>359.37</b>	<b>2</b> polishing pastes	10	359373
<b>359.38</b>	<b>2 assorted</b> polishing pastes	10	359380



PG pack

neutral pack

**FLAP FINISHING WHEEL OF ABRASIVE CLOTH**

Fine sanding - grain **150**

<b>359.40</b>	∅ <b>50 x 25</b> mm - shank ∅ <b>6</b> mm	5	359403
<b>359.42</b>	∅ <b>75 x 45</b> mm - shank ∅ <b>6</b> mm	5	359427
<b>359.44</b>	∅ <b>100 x 50</b> mm - shank ∅ <b>6</b> mm	5	359441
<b>359.70</b>	∅ <b>150 x 25</b> mm - hole ∅ <b>32/20</b> mm	5	359700

**FLAP FINISHING WHEEL OF ABRASIVE AND EMERY CLOTH**

Medium sanding - grain **150**

<b>359.46</b>	∅ <b>50 x 25</b> mm - shank ∅ <b>6</b> mm	5	359465
<b>359.48</b>	∅ <b>75 x 45</b> mm - shank ∅ <b>6</b> mm	5	359489
<b>359.50</b>	∅ <b>100 x 50</b> mm - shank ∅ <b>6</b> mm	5	359502
<b>359.72</b>	∅ <b>150 x 25</b> mm - hole ∅ <b>32/20</b> mm	5	359724

**NYLON FIBER DISC**

<b>359.82</b>	flat ∅ <b>100</b> mm - hole ∅ <b>13</b> mm	5	359823
<b>359.86</b>	depressed centre ∅ <b>115</b> mm - hole ∅ <b>22</b> mm	5	359861

ref.

description

pack  
q.tyEAN13  
8011017**SANDING****SMOOTHING BLOCK** for hand sanding

<b>339.70</b>	<b>125 x 70 mm</b>	10	339702
<b>339.72</b>	<b>125 x 70 mm</b> suitable also for abrasive discs velcro fitting	5	339726

**SANDING SPONGE - 100 x 68 x 25 mm**

<b>339.80</b>	<b>1</b> sanding sponge double grain <b>60/100</b> for wood and metal	10	339801
<b>339.85</b>	<b>24</b> sanding sponges double grain <b>60/100</b> for wood and metal in display box	1	339856

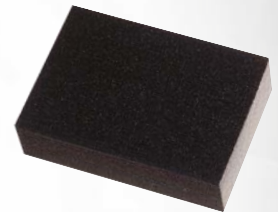
**SANDING SPONGE - 120 x 100 x 12 mm**

<b>339.90</b>	<b>2</b> auto-sponges grain <b>100</b> for metal	10	339900
---------------	--	----	--------

 PG pack

 neutral pack

**PAPER SANDING DISCS - ø 125 mm - coating support 160 g**

<b>340.00</b>	<b>15</b> discs grain <b>50</b>	<input type="checkbox"/>	340005
<b>341.00</b>	<b>15</b> discs grain <b>80</b>	<input type="checkbox"/>	341002
<b>342.00</b>	<b>15</b> discs grain <b>120</b>	<input type="checkbox"/>	342009
<b>343.00</b>	<b>15</b> discs <b>assorted</b> grades	<input type="checkbox"/>	343006

**PAPER SANDING DISCS - ø 125 mm - coating support 230 g**

<b>344.00</b>	<b>5</b> discs grain <b>50</b>	<input type="checkbox"/>	344003
<b>344.10</b>	<b>5</b> discs grain <b>80</b>	<input type="checkbox"/>	344102
<b>344.20</b>	<b>5</b> discs grain <b>120</b>	<input type="checkbox"/>	344201
<b>344.30</b>	<b>5</b> discs <b>assorted</b> grades	<input type="checkbox"/>	344300

**EMERY CLOTH DISCS - ø 125 mm**

<b>350.00</b>	<b>6</b> discs grain <b>40</b>	<input type="checkbox"/>	350004
<b>351.00</b>	<b>6</b> discs grain <b>80</b>	<input type="checkbox"/>	351001
<b>352.00</b>	<b>6</b> discs grain <b>150</b>	<input type="checkbox"/>	352008
<b>353.00</b>	<b>6</b> discs <b>assorted</b> grades	<input type="checkbox"/>	353005

**FIBRE BACKED DISCS - ø 115 mm**

<b>347.00</b>	<b>6</b> discs grain <b>36</b>	<input type="checkbox"/>	347004
<b>347.10</b>	<b>6</b> discs grain <b>60</b>	<input type="checkbox"/>	347103
<b>347.20</b>	<b>6</b> discs grain <b>100</b>	<input type="checkbox"/>	347202

**FIBRE BACKED DISCS - ø 180 mm**

<b>348.00</b>	<b>6</b> discs grain <b>36</b>	<input type="checkbox"/>	348001
<b>348.10</b>	<b>6</b> discs grain <b>60</b>	<input type="checkbox"/>	348100
<b>348.20</b>	<b>6</b> discs grain <b>100</b>	<input type="checkbox"/>	348209

**VELCRO ABRASIVE SHEETS** with dust extraction holes - **93 mm**

<b>348.30</b>	<b>5 sheets grain 40</b>	10	348308
<b>348.31</b>	<b>25 sheets grain 40</b>	1	348315
<b>348.35</b>	<b>5 sheets grain 60</b>	10	348353
<b>348.36</b>	<b>25 sheets grain 60</b>	1	348360
<b>348.40</b>	<b>5 sheets grain 80</b>	10	348407
<b>348.41</b>	<b>25 sheets grain 80</b>	1	348414
<b>348.45</b>	<b>5 sheets grain 120</b>	10	348452
<b>348.46</b>	<b>25 sheets grain 120</b>	1	348469
<b>348.50</b>	<b>5 sheets grain 240</b>	10	348506
<b>348.51</b>	<b>25 sheets grain 240</b>	1	348513
<b>348.56</b>	<b>25 sheets assorted grades</b>	1	348568

**VELCRO ABRASIVE DISCS** -  $\varnothing$  **115 mm**

<b>349.00</b>	<b>10 sheets grain 40</b>	10	349008
<b>349.01</b>	<b>25 sheets grain 40</b>	1	349015
<b>349.10</b>	<b>10 sheets grain 120</b>	10	349107
<b>349.11</b>	<b>25 sheets grain 120</b>	1	349114
<b>349.20</b>	<b>10 sheets grain 240</b>	10	349206
<b>349.21</b>	<b>25 sheets grain 240</b>	1	349213
<b>349.30</b>	<b>10 sheets assorted grades</b>	10	349305
<b>349.31</b>	<b>25 sheets assorted grades</b>	1	349312

**VELCRO ABRASIVE DISCS** -  $\varnothing$  **125 mm**

<b>349.55</b>	<b>10 sheets grain 40</b>	10	349558
<b>349.56</b>	<b>25 sheets grain 40</b>	1	349565
<b>349.60</b>	<b>10 sheets grain 120</b>	10	349602
<b>349.61</b>	<b>25 sheets grain 120</b>	1	349619
<b>349.65</b>	<b>10 sheets grain 240</b>	10	349657
<b>349.66</b>	<b>25 sheets grain 240</b>	1	349664
<b>349.70</b>	<b>10 sheets assorted grades</b>	10	349701
<b>349.71</b>	<b>25 sheets assorted grades</b>	1	349718



**VELCRO ABRASIVE DISCS** with dust extraction holes -  $\varnothing$  **115** mm

<b>349.33</b>	<b>10</b> discs grain <b>40</b>	<input type="checkbox"/>	349336
<b>349.34</b>	<b>25</b> discs grain <b>40</b>	<input type="checkbox"/>	349343
<b>349.35</b>	<b>10</b> discs grain <b>80</b>	<input type="checkbox"/>	349350
<b>349.36</b>	<b>25</b> discs grain <b>80</b>	<input type="checkbox"/>	349367
<b>349.40</b>	<b>10</b> discs grain <b>120</b>	<input type="checkbox"/>	349404
<b>349.41</b>	<b>25</b> discs grain <b>120</b>	<input type="checkbox"/>	349411
<b>349.45</b>	<b>10</b> discs grain <b>240</b>	<input type="checkbox"/>	349459
<b>349.46</b>	<b>25</b> discs grain <b>240</b>	<input type="checkbox"/>	349466
<b>349.50</b>	<b>10</b> sheets <b>assorted</b> grades	<input type="checkbox"/>	349503
<b>349.51</b>	<b>25</b> sheets <b>assorted</b> grades	<input type="checkbox"/>	349510

**VELCRO ABRASIVE DISCS** with dust extraction holes -  $\varnothing$  **125** mm

<b>349.73</b>	<b>10</b> discs grain <b>40</b>	<input type="checkbox"/>	349732
<b>349.74</b>	<b>25</b> discs grain <b>40</b>	<input type="checkbox"/>	349749
<b>349.75</b>	<b>10</b> discs grain <b>80</b>	<input type="checkbox"/>	349756
<b>349.76</b>	<b>25</b> discs grain <b>80</b>	<input type="checkbox"/>	349763
<b>349.80</b>	<b>10</b> discs grain <b>120</b>	<input type="checkbox"/>	349800
<b>349.81</b>	<b>25</b> discs grain <b>120</b>	<input type="checkbox"/>	349817
<b>349.85</b>	<b>10</b> discs grain <b>240</b>	<input type="checkbox"/>	349855
<b>349.86</b>	<b>25</b> discs grain <b>240</b>	<input type="checkbox"/>	349862
<b>349.90</b>	<b>10</b> sheets <b>assorted</b> grades	<input type="checkbox"/>	349909
<b>349.91</b>	<b>25</b> sheets <b>assorted</b> grades	<input type="checkbox"/>	349916

**VELCRO ABRASIVE DISCS** with dust extraction holes -  $\varnothing$  **150** mm

<b>349.95</b>	<b>10</b> discs grain <b>40</b>	<input type="checkbox"/>	349954
<b>349.96</b>	<b>10</b> discs grain <b>80</b>	<input type="checkbox"/>	349961
<b>349.97</b>	<b>10</b> discs grain <b>120</b>	<input type="checkbox"/>	349978
<b>349.98</b>	<b>10</b> discs grain <b>240</b>	<input type="checkbox"/>	349985
<b>349.99</b>	<b>10</b> sheets <b>assorted</b> grades	<input type="checkbox"/>	349992



ref.

description

pack  
q.tyEAN13  
8011017**SANDING****FINISHING PAPER SHEETS - 230 x 280 mm**

<b>355.60</b>	<b>6 sheets grain 60</b>	10	355603
<b>355.62</b>	<b>6 sheets grain 100</b>	10	355627
<b>355.64</b>	<b>6 sheets grain 150</b>	10	355641
<b>355.66</b>	<b>6 sheets assorted grades</b>	10	355665
<b>FC.01</b>	<b>1 sheet grain 40</b>	100	083346
<b>FC.03</b>	<b>1 sheet grain 60</b>	100	083353
<b>FC.04</b>	<b>1 sheet grain 80</b>	100	083360
<b>FC.05</b>	<b>1 sheet grain 100</b>	100	083377
<b>FC.06</b>	<b>1 sheet grain 120</b>	100	083384
<b>FC.07</b>	<b>1 sheet grain 150</b>	100	083391
<b>FC.08</b>	<b>1 sheet grain 180</b>	100	083407

**WET + DRY PAPER SHEETS - 230 x 280 mm**

<b>355.70</b>	<b>6 sheets grain 180</b>	10	355702
<b>355.72</b>	<b>6 sheets grain 320</b>	10	355726
<b>355.74</b>	<b>6 sheets grain 600</b>	10	355740
<b>355.76</b>	<b>6 sheets assorted grades</b>	10	355764
<b>WSC.001</b>	<b>1 sheet grain 100</b>	100	085982
<b>WSC.002</b>	<b>1 sheet grain 120</b>	100	085999
<b>WSC.003</b>	<b>1 sheet grain 150</b>	100	086002
<b>WSC.004</b>	<b>1 sheet grain 180</b>	100	086019
<b>WSC.005</b>	<b>1 sheet grain 220</b>	100	086026
<b>WSC.006</b>	<b>1 sheet grain 240</b>	100	086033
<b>WSC.007</b>	<b>1 sheet grain 280</b>	100	086040
<b>WSC.008</b>	<b>1 sheet grain 320</b>	100	086057
<b>WSC.009</b>	<b>1 sheet grain 360</b>	100	086064
<b>WSC.010</b>	<b>1 sheet grain 400</b>	100	086071
<b>WSC.011</b>	<b>1 sheet grain 500</b>	100	086088
<b>WSC.012</b>	<b>1 sheet grain 600</b>	100	086095

 PG pack

 neutral pack

## EMERY CLOTH SHEETS - 230 x 280 mm



<b>355.80</b>	<b>6 sheets grain 60</b>	10	355801
<b>355.82</b>	<b>6 sheets grain 120</b>	10	355825
<b>355.84</b>	<b>6 sheets grain 240</b>	10	355849
<b>355.86</b>	<b>6 sheets assorted grades</b>	10	355863
<b>T.01</b>	<b>1 sheet grain 30</b>	50	085869
<b>T.03</b>	<b>1 sheet grain 40</b>	50	085876
<b>T.04</b>	<b>1 sheet grain 60</b>	50	085883
<b>T.05</b>	<b>1 sheet grain 80</b>	50	085890
<b>T.06</b>	<b>1 sheet grain 100</b>	50	085906
<b>T.07</b>	<b>1 sheet grain 120</b>	50	085913
<b>T.08</b>	<b>1 sheet grain 150</b>	50	085920
<b>T.09</b>	<b>1 sheet grain 180</b>	50	085937
<b>T.10</b>	<b>1 sheet grain 220</b>	50	085944
<b>T.11</b>	<b>1 sheet grain 240</b>	50	085951
<b>T.12</b>	<b>1 sheet grain 320</b>	50	085968
<b>T.13</b>	<b>1 sheet grain 400</b>	50	085975

## FINISHING PAPER ROLL - 120 mm x 50 yds



<b>RC.01</b>	grain <b>40</b>	1	085159
<b>RC.03</b>	grain <b>60</b>	1	085166
<b>RC.04</b>	grain <b>80</b>	1	085173
<b>RC.05</b>	grain <b>100</b>	1	085180
<b>RC.06</b>	grain <b>120</b>	1	085197
<b>RC.07</b>	grain <b>150</b>	1	085203
<b>RC.08</b>	grain <b>180</b>	1	085210
<b>RC.09</b>	grain <b>240</b>	1	085227

ref.

description

pack  
q.tyEAN13  
8011017**SANDING****FINISHING PAPER ROLL - 120 mm x 5 m**

<b>355.90</b>	grain <b>50</b>	2	355900
<b>355.92</b>	grain <b>80</b>	2	355924
<b>355.94</b>	grain <b>120</b>	2	355948

**VELCRO FINISHING PAPER ROLL - 120 mm x 3 m**

<b>355.96</b>	grain <b>50</b>	2	355962
<b>355.97</b>	grain <b>80</b>	2	355979
<b>355.98</b>	grain <b>120</b>	2	355986

**ORBITAL SANDING SHEETS - 93 x 230 mm**

<b>356.00</b>	<b>10</b> sheets grain <b>50</b>	10	356006
<b>356.01</b>	<b>25</b> sheets grain <b>50</b>	1	356013
<b>356.10</b>	<b>10</b> sheets grain <b>80</b>	10	356105
<b>356.11</b>	<b>25</b> sheets grain <b>80</b>	1	356112
<b>356.20</b>	<b>10</b> sheets grain <b>120</b>	10	356204
<b>356.21</b>	<b>25</b> sheets grain <b>120</b>	1	356211
<b>356.30</b>	<b>10</b> sheets <b>assorted</b> grades	10	356303
<b>356.31</b>	<b>25</b> sheets <b>assorted</b> grades	1	356310

**ORBITAL SANDING SHEETS - 115 x 280 mm**

<b>357.00</b>	<b>10</b> sheets grain <b>50</b>	10	357003
<b>357.01</b>	<b>25</b> sheets grain <b>50</b>	1	357010
<b>357.10</b>	<b>10</b> sheets grain <b>80</b>	10	357102
<b>357.11</b>	<b>25</b> sheets grain <b>80</b>	1	357119
<b>357.20</b>	<b>10</b> sheets grain <b>120</b>	10	357201
<b>357.21</b>	<b>25</b> sheets grain <b>120</b>	1	357218
<b>357.30</b>	<b>10</b> sheets <b>assorted</b> grades	10	357300
<b>357.31</b>	<b>25</b> sheets <b>assorted</b> grades	1	357317

 PG pack

 neutral pack

**VELCRO ABRASIVE SHEETS** with dust extraction holes - **93 x 185** mm  
For Atlas Copco, Bosch, Festo, Holzher, Peugeot



<b>354.00</b>	<b>10</b> sheets grain <b>40</b>	5	354002
<b>354.03</b>	<b>10</b> sheets grain <b>80</b>	5	354033
<b>354.06</b>	<b>10</b> sheets grain <b>120</b>	5	354064
<b>354.09</b>	<b>10</b> sheets grain <b>180</b>	5	354095
<b>354.12</b>	<b>10</b> sheets <b>assorted</b> grades	5	354125

**VELCRO ABRASIVE SHEETS** with dust extraction holes - **93 x 185** mm  
For Black & Decker KA 186, KA 186E



<b>354.15</b>	<b>10</b> sheets grain <b>40</b>	5	354156
<b>354.18</b>	<b>10</b> sheets grain <b>80</b>	5	354187
<b>354.21</b>	<b>10</b> sheets grain <b>120</b>	5	354217
<b>354.24</b>	<b>10</b> sheets grain <b>180</b>	5	354248
<b>354.27</b>	<b>10</b> sheets <b>assorted</b> grades	5	354279

**ABRASIVE SHEETS** with dust extraction holes - **93 x 230** mm  
For Bosch, Festo, Makita, Metabo, Peugeot, Ryobi, Skil, Stayer, Wagner



<b>354.30</b>	<b>10</b> sheets grain <b>40</b>	5	354309
<b>354.33</b>	<b>10</b> sheets grain <b>80</b>	5	354330
<b>354.36</b>	<b>10</b> sheets grain <b>120</b>	5	354361
<b>354.39</b>	<b>10</b> sheets grain <b>180</b>	5	354392
<b>354.42</b>	<b>10</b> sheets <b>assorted</b> grades	5	354422

**ABRASIVE SHEETS** with dust extraction holes - **93 x 230** mm

For AEG, Black &amp; Decker, Bosch, Casals, Einhell, Peugeot

<b>354.45</b>	<b>10</b> sheets grain <b>40</b>	5	354453
<b>354.48</b>	<b>10</b> sheets grain <b>80</b>	5	354484
<b>354.51</b>	<b>10</b> sheets grain <b>120</b>	5	354514
<b>354.54</b>	<b>10</b> sheets grain <b>180</b>	5	354545
<b>354.57</b>	<b>10</b> sheets <b>assorted</b> grades	5	354576

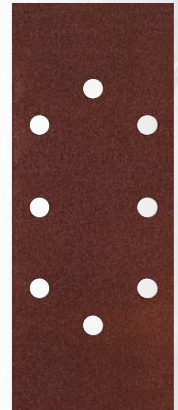
**VELCRO ABRASIVE SHEETS** with dust extraction holes - **115 x 230** mm

For AEG, Bosch, Fein, Festo, Holzher, Kress, Mafell, Makita, Peugeot

<b>354.60</b>	<b>10</b> sheets grain <b>40</b>	5	354606
<b>354.63</b>	<b>10</b> sheets grain <b>80</b>	5	354637
<b>354.66</b>	<b>10</b> sheets grain <b>120</b>	5	354668
<b>354.69</b>	<b>10</b> sheets grain <b>180</b>	5	354699
<b>354.72</b>	<b>10</b> sheets <b>assorted</b> grades	5	354729

**ABRASIVE SHEETS** with dust extraction holes - **115 x 280** mm

For AEG, Atlas Copco, Black &amp; Decker, Bosch, Elu, Fein, Festo

<b>354.75</b>	<b>10</b> sheets grain <b>40</b>	5	354750
<b>354.78</b>	<b>10</b> sheets grain <b>80</b>	5	354781
<b>354.81</b>	<b>10</b> sheets grain <b>120</b>	5	354811
<b>354.84</b>	<b>10</b> sheets grain <b>180</b>	5	354842
<b>354.87</b>	<b>10</b> sheets <b>assorted</b> grades	5	354873



**SANDING BELTS - 400 x 60 mm**

For Bosch PBS 60/60E



<b>355.10</b>	<b>3 belts grain 40</b>	<input type="checkbox"/>	355108
<b>355.11</b>	<b>3 belts grain 60</b>	<input type="checkbox"/>	355115
<b>355.12</b>	<b>3 belts grain 80</b>	<input type="checkbox"/>	355122
<b>355.13</b>	<b>3 belts grain 100</b>	<input type="checkbox"/>	355139
<b>355.14</b>	<b>3 belts grain 150</b>	<input type="checkbox"/>	355146

**SANDING BELTS - 560 x 100 mm**

For Atlas Copco, Elu, Ryobi, Festo



<b>355.15</b>	<b>3 belts grain 40</b>	<input type="checkbox"/>	355153
<b>355.16</b>	<b>3 belts grain 60</b>	<input type="checkbox"/>	355160
<b>355.17</b>	<b>3 belts grain 80</b>	<input type="checkbox"/>	355177
<b>355.18</b>	<b>3 belts grain 100</b>	<input type="checkbox"/>	355184
<b>355.19</b>	<b>3 belts grain 150</b>	<input type="checkbox"/>	355191

**SANDING BELTS - 610 x 100 mm**

For Atlas Copco, Hitachi, Makita, Ryobi, Wolf



<b>355.20</b>	<b>3 belts grain 40</b>	<input type="checkbox"/>	355207
<b>355.21</b>	<b>3 belts grain 60</b>	<input type="checkbox"/>	355214
<b>355.22</b>	<b>3 belts grain 80</b>	<input type="checkbox"/>	355221
<b>355.23</b>	<b>3 belts grain 100</b>	<input type="checkbox"/>	355238
<b>355.24</b>	<b>3 belts grain 150</b>	<input type="checkbox"/>	355245

**SANDING BELTS - 620 x 100 mm**

For Atlas Copco, Bosch, Makita, Metabo

<b>355.25</b>	<b>3 belts grain 40</b>	<input type="checkbox"/>	355252
<b>355.26</b>	<b>3 belts grain 60</b>	<input type="checkbox"/>	355269
<b>355.27</b>	<b>3 belts grain 80</b>	<input type="checkbox"/>	355276
<b>355.28</b>	<b>3 belts grain 100</b>	<input type="checkbox"/>	355283
<b>355.29</b>	<b>3 belts grain 150</b>	<input type="checkbox"/>	355290

ref.

description

pack  
q.tyEAN13  
8011017**SANDING****SANDING BELTS - 533 x 75 mm**

For Bosch PBS 75/75E, Atlas Copco, Metabo, Hitachi, Makita, Holz Her

<b>357.35</b>	<b>3</b> belts grain <b>40</b>	<input type="checkbox"/>	2	357355
<b>357.36</b>	<b>3</b> belts grain <b>60</b>	<input type="checkbox"/>	2	357362
<b>357.37</b>	<b>3</b> belts grain <b>80</b>	<input type="checkbox"/>	2	357379
<b>357.38</b>	<b>3</b> belts grain <b>100</b>	<input type="checkbox"/>	2	357386
<b>357.39</b>	<b>3</b> belts grain <b>150</b>	<input type="checkbox"/>	2	357393

**SANDING BELTS - 410 x 65 mm**

For Black &amp; Decker DN 83/BD 83, Atlas Copco HBS 65, Metabo, Holz Her, Kress

<b>357.40</b>	<b>3</b> belts grain <b>40</b>	<input type="checkbox"/>	3	357409
<b>357.45</b>	<b>3</b> belts grain <b>60</b>	<input type="checkbox"/>	3	357454
<b>357.50</b>	<b>3</b> belts grain <b>80</b>	<input type="checkbox"/>	3	357508
<b>357.55</b>	<b>3</b> belts grain <b>100</b>	<input type="checkbox"/>	3	357553
<b>357.57</b>	<b>3</b> belts grain <b>150</b>	<input type="checkbox"/>	3	357577

**SANDING BELTS - 510 x 75 mm**

For Black &amp; Decker DN 85/BD 85/SR 500 E

<b>357.60</b>	<b>3</b> belts grain <b>40</b>	<input type="checkbox"/>	2	357607
<b>357.65</b>	<b>3</b> belts grain <b>60</b>	<input type="checkbox"/>	2	357652
<b>357.70</b>	<b>3</b> belts grain <b>80</b>	<input type="checkbox"/>	2	357706
<b>357.75</b>	<b>3</b> belts grain <b>100</b>	<input type="checkbox"/>	2	357751
<b>357.77</b>	<b>3</b> belts grain <b>150</b>	<input type="checkbox"/>	2	357775

**SANDING BELTS - 457 x 75 mm**

For B&amp;D KA/85, Stayer LN 75, Skil 1200 H/120 SN, Peugeot, Makita

<b>357.78</b>	<b>3</b> belts grain <b>40</b>	<input type="checkbox"/>	2	357782
<b>357.79</b>	<b>3</b> belts grain <b>60</b>	<input type="checkbox"/>	2	357799
<b>357.80</b>	<b>3</b> belts grain <b>80</b>	<input type="checkbox"/>	2	357805
<b>357.81</b>	<b>3</b> belts grain <b>100</b>	<input type="checkbox"/>	2	357812
<b>357.82</b>	<b>3</b> belts grain <b>150</b>	<input type="checkbox"/>	2	357829

 PG pack neutral pack

**DRUM SANDER**

<b>357.96</b>	∅ 45 x 30 mm - shank ∅ 6 mm	10	357966
<b>357.98</b>	3 sanding belts assorted grades for art. <b>357.96</b>	10	357980

**ROTARY FLAP SANDER** shank ∅ 6 mm - grain **80**

<b>358.40</b>	∅ 40 x 20 mm	10	358406
<b>358.50</b>	∅ 50 x 20 mm	10	358505
<b>358.60</b>	∅ 60 x 40 mm	10	358604
<b>358.80</b>	∅ 80 x 30 mm	10	358802
<b>358.90</b>	<b>40 assorted</b> rotary flap sanders in display box 15 ∅ 40 x 20 mm 15 ∅ 50 x 20 mm 10 ∅ 60 x 30 mm	1	358901

**ROTARY FLAP SANDER**

∅ x thickness x shank (mm)	RPM	grain <b>60</b>		grain <b>80</b>		grain <b>120</b>	
		ref.	EAN13 8011017	ref.	EAN13 8011017	ref.	EAN13 8011017
30 x 10 x 6*	22900	<b>RG.002</b>	085241	<b>RG.037</b>	085418	<b>RG.072</b>	085586
30 x 15 x 6*	22900	<b>RG.004</b>	085258	<b>RG.039</b>	085425	<b>RG.074</b>	085593
30 x 20 x 6*	22900	<b>RG.006</b>	085265	<b>RG.041</b>	085432	<b>RG.076</b>	085609
40 x 10 x 6	17100	<b>RG.011</b>	085272	<b>RG.046</b>	085449	<b>RG.081</b>	085616
40 x 15 x 6	17100	<b>RG.012</b>	085289	<b>RG.047</b>	085456	<b>RG.082</b>	085623
40 x 20 x 6	17100	<b>RG.013</b>	085296	<b>RG.048</b>	085463	<b>RG.083</b>	085630
40 x 30 x 6	17100	<b>RG.015</b>	085302	<b>RG.050</b>	085470	<b>RG.085</b>	085647
50 x 20 x 6	13700	<b>RG.019</b>	085319	<b>RG.054</b>	085487	<b>RG.089</b>	085654
50 x 30 x 6	13700	<b>RG.021</b>	085326	<b>RG.056</b>	085494	<b>RG.091</b>	085661
60 x 20 x 6	11400	<b>RG.024</b>	085333	<b>RG.059</b>	085500	<b>RG.094</b>	085678
60 x 30 x 6	11400	<b>RG.026</b>	085340	<b>RG.061</b>	085517	<b>RG.096</b>	085685
60 x 40 x 6	11400	<b>RG.027</b>	085357	<b>RG.062</b>	085524	<b>RG.097</b>	085692
60 x 50 x 6	11400	<b>RG.028</b>	085364	<b>RG.063</b>	085531	<b>RG.098</b>	085708
80 x 15 x 6	8500	<b>RG.029</b>	085371	<b>RG.064</b>	085548	<b>RG.099</b>	085715
80 x 30 x 6	8500	<b>RG.032</b>	085388	<b>RG.067</b>	085555	<b>RG.102</b>	085722
80 x 40 x 6	8500	<b>RG.033</b>	085395	<b>RG.068</b>	085562	<b>RG.103</b>	085739
80 x 50 x 6	8500	<b>RG.034</b>	085401	<b>RG.069</b>	085579	<b>RG.104</b>	085746

\* On demand available with shank ∅ 3 mm - Packing: 10 pcs.

PG pack  neutral pack





ref.

description

pack  
q.tyEAN13  
8011017**CUTTING AND  
GRINDING****FLAP SANDING DISC - NYLON SUPPORT**

<b>358.00</b>	ø <b>115</b> mm - hole ø <b>22</b> mm - grain <b>80</b>	10	358000
<b>358.10</b>	ø <b>115</b> mm - hole ø <b>22</b> mm - grain <b>40</b>	10	358109
<b>358.15</b>	ø <b>115</b> mm - hole ø <b>22</b> mm - grain <b>80</b>	10	358154
<b>358.20</b>	ø <b>115</b> mm - hole ø <b>22</b> mm - grain <b>120</b>	10	358208

**FLAP SANDING DISC - NYLON SUPPORT**

<b>358.05</b>	ø <b>180</b> mm - hole ø <b>22</b> mm - grain <b>80</b>	10	358055
<b>358.25</b>	ø <b>180</b> mm - hole ø <b>22</b> mm - grain <b>40</b>	10	358253
<b>358.30</b>	ø <b>180</b> mm - hole ø <b>22</b> mm - grain <b>80</b>	10	358307
<b>358.35</b>	ø <b>180</b> mm - hole ø <b>22</b> mm - grain <b>120</b>	10	358352

**KNIFE AND SCISSOR SHARPENER**

<b>395.00</b>	ø <b>50</b> mm - hexagonal shank <b>7</b> mm	10	395005
---------------	--	----	--------

**SHARPENING STONE**

<b>395.20</b>	<b>230</b> mm	10	395203
<b>395.40</b>	<b>230</b> mm	100	395401



PG pack

neutral pack

**MOUNTED GRINDING POINTS - PINK CORUNDUM**

For metal, glass, ceramics, plastics



**396.00** 100 assorted mounted grinding points - shank  $\varnothing$  6 mm - in display box

1

396002



**MOUNTED GRINDING POINTS - PINK CORUNDUM**

For metal, glass, ceramics, plastics

**397.00** 45 assorted mounted grinding points - shank  $\varnothing$  3/6 mm - in display holder

1

397009



**MOUNTED GRINDING POINTS - PINK CORUNDUM**

For metal, glass, ceramics, plastics



**397.60** 3 assorted chain saw sharpening points - shank  $\varnothing$  3 mm

10

397603

**398.00** 5 assorted mounted grinding points - shank  $\varnothing$  3 mm

10

398006

**399.00** 5 assorted mounted grinding points - shank  $\varnothing$  6 mm

10

399003

∅ x  
thickness  
x hole  
(mm)

ref.

EAN13  
8011017

∅ x  
thickness  
x hole  
(mm)

ref.

EAN13  
8011017

∅ x  
thickness  
x hole  
(mm)

ref.

EAN13  
8011017

**CUTTING AND  
GRINDING**

## MOUNTED GRINDING POINT - PINK CORUNDUM STRAIGHT SHAPE A

2 x 6 x 3	<b>MA.001</b>	083681	12 x 20 x 6	<b>MA.019</b>	083865	30 x 25 x 6	<b>MA.037</b>	084046
3 x 6 x 3	<b>MA.002</b>	083698	12 x 30 x 6	<b>MA.020</b>	083872	30 x 30 x 6	<b>MA.038</b>	084053
4 x 8 x 3	<b>MA.003</b>	083704	15 x 15 x 6	<b>MA.021</b>	083889	30 x 40 x 6	<b>MA.039</b>	084060
5 x 10 x 3	<b>MA.004</b>	083711	15 x 20 x 6	<b>MA.022</b>	083896	35 x 20 x 6	<b>MA.040</b>	084077
6 x 10 x 3	<b>MA.005</b>	083728	15 x 25 x 6	<b>MA.023</b>	083902	35 x 25 x 6	<b>MA.041</b>	084084
8 x 10 x 3	<b>MA.006</b>	083735	15 x 30 x 6	<b>MA.024</b>	083919	35 x 35 x 6	<b>MA.042</b>	084091
10 x 10 x 3	<b>MA.007</b>	083742	15 x 40 x 6	<b>MA.025</b>	083926	40 x 20 x 6	<b>MA.043</b>	084107
12 x 12 x 3	<b>MA.008</b>	083759	20 x 15 x 6	<b>MA.026</b>	083933	40 x 25 x 6	<b>MA.044</b>	084114
15 x 15 x 3	<b>MA.009</b>	083766	20 x 20 x 6	<b>MA.027</b>	083940	40 x 30 x 6	<b>MA.045</b>	084121
4 x 8 x 6	<b>MA.010</b>	083773	20 x 25 x 6	<b>MA.028</b>	083957	40 x 40 x 6	<b>MA.046</b>	084138
5 x 10 x 6	<b>MA.011</b>	083780	20 x 30 x 6	<b>MA.029</b>	083964	50 x 25 x 6	<b>MA.047</b>	084145
6 x 10 x 6	<b>MA.012</b>	083797	20 x 40 x 6	<b>MA.030</b>	083971	50 x 30 x 6	<b>MA.048</b>	084152
8 x 10 x 6	<b>MA.013</b>	083803	25 x 15 x 6	<b>MA.031</b>	083988	50 x 40 x 6	<b>MA.049</b>	084169
10 x 10 x 6	<b>MA.014</b>	083810	25 x 20 x 6	<b>MA.032</b>	083995			
10 x 15 x 6	<b>MA.015</b>	083827	25 x 25 x 6	<b>MA.033</b>	084008			
10 x 20 x 6	<b>MA.016</b>	083834	25 x 30 x 6	<b>MA.034</b>	084015			
10 x 30 x 6	<b>MA.017</b>	083841	25 x 40 x 6	<b>MA.035</b>	084022			
12 x 12 x 6	<b>MA.018</b>	083858	30 x 20 x 6	<b>MA.036</b>	084039			

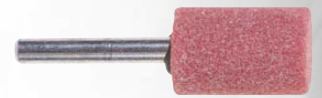

## CENTRE POINT CONE SHAPE B

10 x 15 x 3	<b>MB.001</b>	084190	15 x 25 x 6	<b>MB.004</b>	084220	30 x 40 x 6	<b>MB.007</b>	084251
10 x 15 x 6	<b>MB.002</b>	084206	20 x 30 x 6	<b>MB.005</b>	084237			
10 x 20 x 6	<b>MB.003</b>	084213	25 x 30 x 6	<b>MB.006</b>	084244			



## CYLINDRICAL CONE SHAPE C

6 x 8 x 3	<b>MC.001</b>	084268	10 x 15 x 6	<b>MC.005</b>	084305	20 x 30 x 6	<b>MC.009</b>	084343
8 x 12 x 3	<b>MC.002</b>	084275	10 x 20 x 6	<b>MC.006</b>	084312	20 x 40 x 6	<b>MC.010</b>	084350
8 x 12 x 6	<b>MC.003</b>	084282	15 x 20 x 6	<b>MC.007</b>	084329	25 x 40 x 6	<b>MC.011</b>	084367
8 x 20 x 6	<b>MC.004</b>	084299	15 x 25 x 6	<b>MC.008</b>	084336	30 x 40 x 6	<b>MC.012</b>	084374



## FLAT SHAPE D

10 x 3,5 x 3	<b>MD.001</b>	084381	30 x 6 x 6	<b>MD.008</b>	084459	40 x 15 x 6	<b>MD.015</b>	084527
10 x 5 x 3	<b>MD.002</b>	084398	30 x 10 x 6	<b>MD.009</b>	084466	50 x 10 x 6	<b>MD.016</b>	084534
15 x 4 x 3	<b>MD.003</b>	084404	30 x 15 x 6	<b>MD.010</b>	084473	50 x 15 x 6	<b>MD.017</b>	084541
20 x 4 x 3	<b>MD.004</b>	084411	35 x 8 x 6	<b>MD.011</b>	084480	60 x 10 x 6	<b>MD.018</b>	084558
20 x 10 x 6	<b>MD.005</b>	084428	35 x 12 x 6	<b>MD.012</b>	084497	70 x 10 x 6	<b>MD.019</b>	084565
25 x 5 x 6	<b>MD.006</b>	084435	40 x 6 x 6	<b>MD.013</b>	084503			
25 x 10 x 6	<b>MD.007</b>	084442	40 x 10 x 6	<b>MD.014</b>	084510			



## BALL SHAPE E

4 x 3	<b>ME.001</b>	084572	10 x 3	<b>ME.004</b>	084602	20 x 6	<b>ME.007</b>	084633
6 x 3	<b>ME.002</b>	084589	10 x 6	<b>ME.005</b>	084619	25 x 6	<b>ME.008</b>	084640
8 x 3	<b>ME.003</b>	084596	15 x 6	<b>ME.006</b>	084626	30 x 6	<b>ME.009</b>	084657

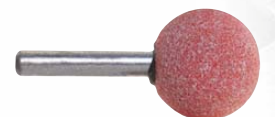

Packing: 10 pcs

PG pack

neutral pack

**MOUNTED GRINDING POINT - PINK CORUNDUM CONICAL SHAPE F**



8 x 12 x 3	<b>MF.001</b>	084671	20 x 25 x 6	<b>MF.004</b>	084701	30 x 40 x 6	<b>MF.007</b>	084732
10 x 15 x 3	<b>MF.002</b>	084688	25 x 30 x 6	<b>MF.005</b>	084718			
10 x 15 x 6	<b>MF.003</b>	084695	30 x 30 x 6	<b>MF.006</b>	084725			

**ROUNDED SHAPE G**



20 x 10 x 6	<b>MG.001</b>	084756	40 x 10 x 6	<b>MG.003</b>	084770			
30 x 10 x 6	<b>MG.002</b>	084763	40 x 20 x 6	<b>MG.004</b>	084787			

**DOUBLE CHAMFER SHAPE H**

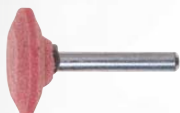

20 x 6 x 6	<b>MH.001</b>	084794	40 x 10 x 6	<b>MH.003</b>	084817			
30 x 10 x 6	<b>MH.002</b>	084800	50 x 10 x 6	<b>MH.004</b>	084824			

**ROUND HEAD SHAPE I**

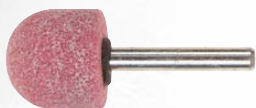

10 x 10 x 3	<b>MI.001</b>	084831	15 x 15 x 6	<b>MI.004</b>	084862	30 x 30 x 6	<b>MI.007</b>	084893
10 x 20 x 6	<b>MI.002</b>	084848	20 x 20 x 6	<b>MI.005</b>	084879			
12 x 12 x 6	<b>MI.003</b>	084855	25 x 25 x 6	<b>MI.006</b>	084886			

**POINTED ARCH SHAPE L**

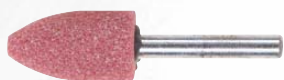

6 x 10 x 3	<b>ML.001</b>	084916	10 x 15 x 6	<b>ML.004</b>	084947	18 x 32 x 6	<b>ML.007</b>	084978
8 x 10 x 3	<b>ML.002</b>	084923	12 x 20 x 6	<b>ML.005</b>	084954	20 x 40 x 6	<b>ML.008</b>	084985
8 x 10 x 6	<b>ML.003</b>	084930	15 x 20 x 6	<b>ML.006</b>	084961			

**CUP SHAPE M**

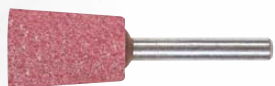

10 x 20 x 3	<b>MM.001</b>	084992	20 x 20 x 6	<b>MM.004</b>	085029	30 x 30 x 6	<b>MM.007</b>	085050
12 x 20 x 6	<b>MM.002</b>	085005	20 x 30 x 6	<b>MM.005</b>	085036	40 x 20 x 6	<b>MM.008</b>	085067
15 x 20 x 6	<b>MM.003</b>	085012	30 x 20 x 6	<b>MM.006</b>	085043	40 x 30 x 6	<b>MM.009</b>	085074

**TRUNCATED-CONE SHAPE N**



8 x 10 x 3	<b>MN.001</b>	085081	12 x 20 x 6	<b>MN.004</b>	085111	25 x 40 x 6	<b>MN.007</b>	085142
8 x 15 x 3	<b>MN.002</b>	085098	15 x 25 x 6	<b>MN.005</b>	085128			
10 x 15 x 6	<b>MN.003</b>	085104	20 x 30 x 6	<b>MN.006</b>	085135			

Packing: 10 pcs

PG pack

neutral pack

ref.

description

pack  
q.tyEAN13  
8011017**CUTTING AND  
GRINDING****GRINDING WHEEL - GREY CORUNDUM**

<b>400.00</b>	ø 75 x 10 mm - hole ø 10 mm	10	400006
<b>402.00</b>	ø 75 x 10 mm - hole ø 13 mm	10	402000
<b>403.00</b>	ø 75 x 10 mm - hole ø 13 mm - <b>SILICON CARBIDE</b>	10	403007
<b>404.00</b>	ø 100 x 12 mm - hole ø 13 mm	10	404004
<b>404.50</b>	ø 125 x 15 mm - hole ø 16 mm	10	404509
<b>405.00</b>	ø 150 x 20 mm - hole ø 16 mm	10	405001

**WET GRINDING WHEEL - WHITE CORUNDUM**

<b>880.00</b>	ø 100 x 20 x 16 mm for drills with ø 43 mm collar - <b>CE</b>	1	880006
<b>882.00</b>	replacement grinding wheel ø 100 x 20 x 16 mm for art. <b>880.00</b>	1	882000

**WHEEL DRESSERS C48 20T - SILICON CARBIDE**

dimensions (mm)	ref.	
150 x 20	C48.01	
200 x 20	C48.02	
200 x 25	C48.03	

Packing:  2 pcs.**DOUBLE GRAIN WET STONES**

dimensions (mm)	C49 green silicon carbide grain 120/400		A99 ruby corundum grain 150/320	
leng. x width x thick.	ref.		ref.	
125 x 50 x 20	DG.01		DG.03	
150 x 50 x 25	DG.02		DG.04	

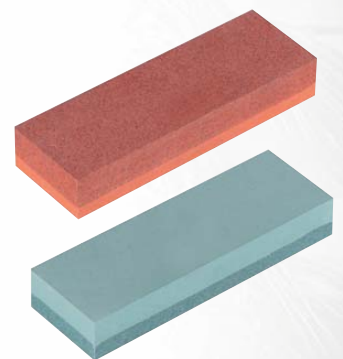
Packing:  1 pcs.**ABRASIVE FILES - PINK CORUNDUM**

dimensions (mm)	grain 80		grain 120		grain 220		SHAPE
	ref.		ref.		ref.		
100 x 13	LTR.001		LTR.004		LTR.007		triangular
150 x 16	LTR.002		LTR.005		LTR.008		
200 x 20	LTR.003		LTR.006		LTR.009		
100 x 13	LTO.001		LTO.004		LTO.007		half-round
150 x 16	LTO.002		LTO.005		LTO.008		
200 x 20	LTO.003		LTO.006		LTO.009		
100 x 13	LQU.001		LQU.004		LQU.007		square
150 x 16	LQU.002		LQU.005		LQU.008		
200 x 20	LQU.003		LQU.006		LQU.009		

 PG pack neutral packPacking:  10 pcs.



**GRINDING WHEELS**

**A96 GREY CORUNDUM**

**C49 GREEN SILICON CARBIDE**

dimensions (mm) ø x thickness x hole	grains						grain
	24	36	46	60	80	100	
75 x 10 x 10				A96.053	A96.078	A96.102	C49.010
75 x 12 x 13				A96.054	A96.079	A96.103	C49.011
100 x 10 x 13				A96.055	A96.080	A96.104	
100 x 13 x 13		A96.204	A96.209	A96.056	A96.214	A96.105	C49.012
100 x 15 x 13	A96.199	A96.205	A96.210	A96.057	A96.082	A96.106	C49.013
100 x 20 x 13	A96.200	A96.206	A96.211	A96.058	A96.083	A96.107	C49.050
125 x 13 x 16		A96.157	A96.166	A96.175	A96.185	A96.191	
125 x 15 x 16	A96.149	A96.158	A96.167	A96.176	A96.186	A96.192	C49.034
125 x 20 x 16	A96.150	A96.127	A96.168	A96.177	A96.187	A96.193	C49.035
125 x 25 x 16	A96.151	A96.160	A96.169	A96.178	A96.188	A96.194	
150 x 16 x 16	A96.001	A96.019	A96.038	A96.063	A96.088	A96.112	C49.051
150 x 20 x 16	A96.002	A96.020	A96.039	A96.064	A96.089	A96.113	C49.016
150 x 20 x 32		A96.207		A96.212			
150 x 25 x 16	A96.003	A96.021	A96.040	A96.065	A96.090	A96.114	C49.017
150 x 30 x 16	A96.004	A96.022	A96.041	A96.066	A96.091	A96.115	
175 x 20 x 20	A96.005	A96.023	A96.042	A96.067	A96.092	A96.116	C49.018
175 x 25 x 20	A96.006	A96.024	A96.043	A96.068	A96.093	A96.117	C49.052
200 x 20 x 20	A96.008	A96.026	A96.045	A96.070	A96.095	A96.119	C49.019
200 x 20 x 32		A96.208		A96.213			
200 x 25 x 20	A96.009	A96.027	A96.046	A96.071	A96.096	A96.120	C49.020
200 x 30 x 20	A96.010	A96.028	A96.047	A96.072	A96.097	A96.121	C49.053
250 x 25 x 25	A96.011	A96.029	A96.048	A96.073	A96.098	A96.122	C49.054
250 x 30 x 25	A96.012	A96.030	A96.049	A96.074	A96.099	A96.123	C49.055
300 x 30 x 30	A96.013	A96.031	A96.050	A96.075	A96.100	A96.124	
300 x 35 x 30	A96.147	A96.155	A96.164	A96.173	A96.182		
300 x 40 x 30	A96.014	A96.032	A96.051	A96.076	A96.101		
400 x 50 x 40	A96.148	A96.033	A96.052	A96.077	A96.184		

**TWO SIDE TAPERED WHEELS - grain 80**



dimensions (mm) ø x thickness x hole	A96 grey corundum		A99 white corundum		dimensions ø x thickness x hole	A96 grey corundum		A99 white corundum	
	ref.		ref.			ref.		ref.	
125 x 6 x 16	A96.C01		A99.C01		175 x 8 x 20	A96.C08		A99.C08	
125 x 7 x 16	A96.C02		A99.C02		175 x 10 x 20	A96.C09		A99.C09	
125 x 8 x 16	A96.C03		A99.C03		200 x 6 x 20	A96.C10		A99.C10	
150 x 6 x 16	A96.C04		A99.C04		200 x 8 x 20	A96.C11		A99.C11	
150 x 7 x 16	A96.C05		A99.C05		200 x 10 x 20	A96.C12		A99.C12	
150 x 8 x 16	A96.C06		A99.C06		200 x 12 x 20	A96.C14			
150 x 10 x 16	A96.C13		A99.C13		250 x 10 x 25	A96.C15			
175 x 6 x 20	A96.C07		A99.C07		250 x 13 x 25	A96.C16			

Packing:  pcs.

PG pack  neutral pack

∅ x thickness x hole  
(mm)

for **CUTTING**

for **GRINDING**

pack  
q.ty

EAN13  
8011017

**CUTTING AND  
GRINDING**

**DISC for metal**

115 x 1,0 x 22	<b>406.95</b>	-	10	406954
115 x 1,6 x 22	<b>407.00</b>	-	10	407005
115 x 1,6 x 22	<b>407.05</b>	-	10	407050
125 x 2,5 x 13	<b>406.00</b>	-	10	406008



**DISC for stone**

115 x 1,6 x 22	<b>409.00</b>	-	10	409009
115 x 1,6 x 22	<b>409.05</b>	-	10	409054
125 x 2,5 x 13	<b>408.00</b>	-	10	408002



**REINFORCED DEPRESSED CENTRE DISC for metal**

115 x 3,2 x 22	<b>413.00</b>	-	10	413006
115 x 3,2 x 22	<b>413.05</b>	-	10	413051
115 x 6,4 x 22	-	<b>414.00</b>	10	414003
115 x 6,4 x 22	-	<b>414.05</b>	10	414058



**REINFORCED DEPRESSED CENTRE DISC for stone**

115 x 3,2 x 22	<b>413.50</b>	-	10	413501
115 x 3,2 x 22	<b>413.55</b>	-	10	413556
115 x 6,4 x 22	-	<b>414.50</b>	10	414508
115 x 6,4 x 22	-	<b>414.55</b>	10	414553



PG pack

neutral pack



**UNIVERSAL DIAMOND CUTTING DISC TURBO**

For cutting of reinforced concrete, roofing tiles, facing, granite

<b>419.60</b>	Ø 115 mm - hole Ø 22 mm	1	419602
<b>419.65</b>	Ø 230 mm - hole Ø 22 mm	1	419657



**SEGMENTED DIAMOND CUTTING DISC**

For cutting of tiles, natural stone, cobblestones, paving slabs

<b>419.70</b>	Ø 115 mm - hole Ø 22 mm	1	419701
<b>419.75</b>	Ø 230 mm - hole Ø 22 mm	1	419756



**DIAMOND CUTTING DISC WITH CONTINUOUS EDGE**

For cutting of tiles, ceramic tiles, half-bricks, marble

<b>419.80</b>	Ø 115 mm - hole Ø 22 mm	1	419800
<b>419.85</b>	Ø 230 mm - hole Ø 22 mm	1	419855



**WOOD CUTTING DISC**

For milling, cutting and chamfering wood and working on PVC and plastics





<b>419.90</b>	Ø 115 mm - hole Ø 22 mm	5	419909
<b>419.95</b>	Ø 230 mm - hole Ø 22 mm	1	419954



ref.

description

pack  
q.tyEAN13  
8011017**MILLING****WOOD CUTTER - shank  $\varnothing$  8 mm**

<b>363.00</b>	$\varnothing$ 35 mm rounding off cutter		5	363004
<b>364.50</b>	$\varnothing$ 25 x 22 mm rounding off cutter		5	364506
<b>368.00</b>	$\varnothing$ 30 x 1,5 mm slotting cutter		5	368009
<b>369.00</b>	$\varnothing$ 30 x 2,5 mm slotting cutter		5	369006
<b>370.00</b>	$\varnothing$ 45 x 1,5 mm slotting saw		5	370002

**ADJUSTABLE HAND SHAPER** to be used with wood cutters

<b>373.00</b>	adjustable hand shaper with slotting saw $\varnothing$ 45 mm - <b>CE</b>		1	373003
---------------	--	--	---	--------

**ADJUSTABLE COUNTERSINK** complete with wood drill bit and depth stop

<b>374.03</b>	$\varnothing$ 3 mm		10	374031
<b>374.04</b>	$\varnothing$ 4 mm		10	374048
<b>374.05</b>	$\varnothing$ 5 mm		10	374055
<b>374.06</b>	$\varnothing$ 6 mm		10	374062



PG pack

neutral pack

**COUNTERSINK - shank ø 6 mm**

<b>375.00</b>	ø 6 mm	10	375007
<b>376.00</b>	ø 12 mm	10	376004
<b>377.00</b>	ø 16 mm	10	377001
<b>378.00</b>	ø 19 mm	10	378008

**COUNTERSINK - shank ø 5 mm**

<b>379.00</b>	ø 13 mm	10	379005
---------------	---------	----	--------

**COUNTERSINK - hexagonal shank 1/4"**

<b>451.10</b>	ø 10 mm	5	451107
---------------	---------	---	--------

**HAND COUNTERSINK**

<b>451.00</b>	ø 12 mm - 5 cutters	10	451008
---------------	---------------------	----	--------

**HINGE BORING BIT - shank ø 8 mm**

<b>379.50</b>	ø 20 mm	10	379500
<b>380.00</b>	ø 26 mm	10	380001
<b>381.00</b>	ø 30 mm	10	381008
<b>382.00</b>	ø 35 mm	10	382005
<b>383.00</b>	ø 38 mm	10	383002

**HINGE BORING BIT CARBIDE TIPPED - shank ø 8 mm**

<b>384.00</b>	ø 26 mm	5	384009
<b>384.10</b>	ø 30 mm	5	384108
<b>384.20</b>	ø 35 mm	5	384207



ref.

description

pack  
q.tyEAN13  
8011017**FLAT WOOD  
DRILLS AND  
FORSTNER BITS****FLAT WOOD BORING DRILL BIT - shank  $\varnothing$  6 mm**

<b>384.50</b>	$\varnothing$ 6 mm	10	384504
<b>385.00</b>	$\varnothing$ 8 mm	10	385006
<b>386.00</b>	$\varnothing$ 10 mm	10	386003
<b>387.00</b>	$\varnothing$ 12 mm	10	387000
<b>388.00</b>	$\varnothing$ 14 mm	10	388007
<b>389.00</b>	$\varnothing$ 16 mm	10	389004
<b>390.00</b>	$\varnothing$ 18 mm	10	390000
<b>391.00</b>	$\varnothing$ 20 mm	10	391007
<b>392.00</b>	$\varnothing$ 22 mm	10	392004
<b>392.50</b>	$\varnothing$ 24 mm	10	392509
<b>393.00</b>	$\varnothing$ 25 mm	10	393001
<b>393.20</b>	$\varnothing$ 26 mm	10	393209
<b>393.40</b>	$\varnothing$ 28 mm	10	393407
<b>393.60</b>	$\varnothing$ 30 mm	10	393605
<b>394.00</b>	$\varnothing$ 32 mm	10	394008
<b>394.20</b>	$\varnothing$ 35 mm	10	394206
<b>394.40</b>	$\varnothing$ 38 mm	10	394404

**EXPANSIVE WOOD BORING DRILL BIT**

<b>394.70</b>	$\varnothing$ 15/45 mm - shank $\varnothing$ 6 mm	2	394701
<b>394.80</b>	$\varnothing$ 22/76 mm - shank $\varnothing$ 10 mm	2	394800

**EXTENSION SHANK FOR FLAT WOOD DRILLS - shank  $\varnothing$  6 mm**

<b>394.84</b>	150 mm	5	394848
<b>394.86</b>	300 mm	5	394862

 PG pack

 neutral pack

**FORSTNER BIT - DIN 7483**  
90 mm lenght - shank  $\varnothing$  8 mm



<b>12.010</b>	$\varnothing$ 10 mm	1	120102
<b>12.012</b>	$\varnothing$ 12 mm	1	120126
<b>12.014</b>	$\varnothing$ 14 mm	1	120140
<b>12.015</b>	$\varnothing$ 15 mm	1	120157
<b>12.016</b>	$\varnothing$ 16 mm	1	120164
<b>12.018</b>	$\varnothing$ 18 mm	1	120188
<b>12.020</b>	$\varnothing$ 20 mm	1	120201
<b>12.022</b>	$\varnothing$ 22 mm	1	120225
<b>12.024</b>	$\varnothing$ 24 mm	1	120249
<b>12.025</b>	$\varnothing$ 25 mm	1	120256
<b>12.026</b>	$\varnothing$ 26 mm	1	120263
<b>12.028</b>	$\varnothing$ 28 mm	1	120287
<b>12.030</b>	$\varnothing$ 30 mm	1	120300
<b>12.032</b>	$\varnothing$ 32 mm - shank $\varnothing$ 10 mm	1	120324
<b>12.034</b>	$\varnothing$ 34 mm - shank $\varnothing$ 10 mm	1	120348
<b>12.035</b>	$\varnothing$ 35 mm - shank $\varnothing$ 10 mm	1	120355
<b>12.036</b>	$\varnothing$ 36 mm - shank $\varnothing$ 10 mm	1	120362
<b>12.040</b>	$\varnothing$ 40 mm - shank $\varnothing$ 10 mm	1	120409
<b>12.045</b>	$\varnothing$ 45 mm - shank $\varnothing$ 10 mm	1	120454
<b>12.050</b>	$\varnothing$ 50 mm - shank $\varnothing$ 10 mm	1	120508

ref.

description

pack  
q.tyEAN13  
8011017**RASPING****ROTARY FILE** for metal - shank  $\varnothing$  6 mm

<b>420.00</b>	cylindrical rotary file $\varnothing$ 12 x 30 mm	10	420004
<b>422.00</b>	conical rotary file $\varnothing$ 6/15 x 35 mm	10	422008
<b>424.00</b>	cylindrical rounded rotary file $\varnothing$ 12 x 30 mm	10	424002
<b>426.00</b>	spherical rotary file $\varnothing$ 15 mm	10	426006

**ROTARY FILE** for metal - shank 1/4"

<b>445.20</b>	conical rotary file $\varnothing$ 6/14 x 35 mm	5	445205
<b>445.30</b>	cylindrical rounded rotary file $\varnothing$ 12 x 30 mm	5	445304

**ROTARY RASP** for wood - shank  $\varnothing$  6 mm

<b>430.00</b>	cylindrical rotary rasp $\varnothing$ 16 x 30 mm	10	430003
<b>432.00</b>	conical rotary rasp $\varnothing$ 6/15 x 35 mm	10	432007
<b>434.00</b>	spherical rotary rasp $\varnothing$ 15 mm	10	434001
<b>436.00</b>	dome rotary rasp $\varnothing$ 12/16 x 30 mm	10	436005
<b>438.00</b>	rotary countersink $\varnothing$ 13 x 30 mm	10	438009

**ROTARY RASP** for wood - shank 1/4"

<b>440.20</b>	conical rotary rasp $\varnothing$ 6/14 x 33 mm	5	440200
<b>440.40</b>	cylindrical rounded rotary rasp $\varnothing$ 15 x 35 mm	5	440408

**HSS DRILL SAW** for metal and wood - shank  $\varnothing$  6 mm

<b>445.00</b>	$\varnothing$ 6 x 85 mm	10	445007
---------------	-------------------------	----	--------

**ASSORTED FILES AND RASPS** for metal and wood - shank  $\varnothing$  6 mm

<b>446.00</b>	3 assorted rotary rasps	10	446004
<b>447.00</b>	6 assorted rotary files and rasps	5	447001

 PG pack

 neutral pack

**WOOD RASP - shank  $\varnothing$  6 mm**

<b>448.00</b>	$\varnothing$ 10/15 mm	10	448008
---------------	------------------------	----	--------

**FILE AND RASP for metal and wood**

<b>449.06</b>	length 6" - 150 mm	10	449067
---------------	--------------------	----	--------

<b>449.08</b>	length 8" - 200 mm	10	449081
---------------	--------------------	----	--------

**ASSORTED FILES - 4" length - 100 mm**

<b>449.20</b>	6 files equalling - flat - halfround - round - three square - square shape	5	449203
---------------	--	---	--------

**ROUND CHAIN SAW FILES - 8" length - 200 mm**

<b>449.40</b>	2 files $\varnothing$ 5/32" - 4,0 mm	10	449401
---------------	--------------------------------------	----	--------

<b>449.45</b>	12 files $\varnothing$ 5/32" - 4,0 mm	2	449456
---------------	---------------------------------------	---	--------

<b>449.50</b>	2 files $\varnothing$ 3/16" - 4,8 mm	10	449500
---------------	--------------------------------------	----	--------

<b>449.55</b>	12 files $\varnothing$ 3/16" - 4,8 mm	2	449555
---------------	---------------------------------------	---	--------

<b>449.60</b>	2 files $\varnothing$ 7/32" - 5,6 mm	10	449609
---------------	--------------------------------------	----	--------

<b>449.65</b>	12 files $\varnothing$ 7/32" - 5,6 mm	2	449654
---------------	---------------------------------------	---	--------

**MAGNETIC BIT HOLDER**For bits with hexagonal shank **1/4"**

<b>452.00</b>	hexagonal shank <b>1/4"</b> - <b>60</b> mm length	10	452005
<b>452.05</b>	with quick release - hexagonal shank <b>1/4"</b> - <b>60</b> mm length	5	452050
<b>452.10</b>	with ring magnet and depth stop - hexagonal shank <b>1/4"</b> <b>60</b> mm length - for drywall	5	452104
<b>452.15</b>	flexible - hexagonal shank <b>1/4"</b> - <b>190</b> mm length	5	452159
<b>452.20</b>	<b>SDS-plus</b> shank - <b>75</b> mm length	5	452203

**90° ANGLE SCREWDRIVER**

<b>452.30</b>	with hexagonal receptacle <b>1/4"</b>	5	452302
---------------	---------------------------------------	---	--------

**BITS FOR TORX SCREWS - 25 mm length**

<b>452.40</b>	2 bits <b>T10</b>	10	452401
<b>452.50</b>	2 bits <b>T15</b>	10	452500
<b>452.60</b>	2 bits <b>T20</b>	10	452609
<b>452.70</b>	2 bits <b>T25</b>	10	452708
<b>452.80</b>	2 bits <b>T30</b>	10	452807
<b>452.90</b>	2 bits <b>T40</b>	10	452906

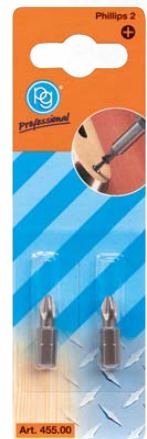
**TITANIUM BITS FOR TORX SCREWS - 25 mm length**

<b>452.92</b>	2 bits <b>T10</b>	5	452920
<b>452.93</b>	2 bits <b>T15</b>	5	452937
<b>452.94</b>	2 bits <b>T20</b>	5	452944
<b>452.95</b>	2 bits <b>T25</b>	5	452951
<b>452.96</b>	2 bits <b>T30</b>	5	452968
<b>452.97</b>	2 bits <b>T40</b>	5	452975



**ALLEN KEY BITS - 25 mm length**

<b>453.00</b>	2 bits 2 mm	10	453002
<b>453.10</b>	2 bits 2,5 mm	10	453101
<b>453.20</b>	2 bits 3 mm	10	453200
<b>453.30</b>	2 bits 4 mm	10	453309
<b>453.40</b>	2 bits 5 mm	10	453408
<b>453.50</b>	2 bits 6 mm	10	453507

**PHILLIPS BITS - 25 mm length**

<b>454.00</b>	2 bits n. 1	10	454009
<b>455.00</b>	2 bits n. 2	10	455006
<b>456.00</b>	2 bits n. 3	10	456003
<b>456.20</b>	1 bit n. 4	10	456201

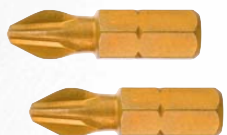
**TITANIUM PHILLIPS BITS - 25 mm length**

<b>456.50</b>	2 bits n. 1	5	456508
<b>456.52</b>	2 bits n. 2	5	456522
<b>456.54</b>	2 bits n. 3	5	456546

**SLOT BITS - 25 mm length**

<b>457.00</b>	2 bits 0,8 x 4 mm	10	457000
<b>458.00</b>	2 bits 0,8 x 5 mm	10	458007
<b>459.00</b>	2 bits 1,0 x 6 mm	10	459004
<b>459.20</b>	2 bits 1,2 x 7,2 mm	10	459202
<b>459.40</b>	2 bits 1,6 x 8 mm	10	459400

**TITANIUM SLOT BITS - 25 mm length**

<b>459.50</b>	2 bits 0,8 x 4 mm	5	459509
<b>459.52</b>	2 bits 0,8 x 5 mm	5	459523
<b>459.54</b>	2 bits 1,0 x 6 mm	5	459547



ref.

description

pack  
q.tyEAN13  
8011017

BITS

**POZIDRIV BITS - 25 mm length**

<b>459.90</b>	<b>2 bits n. 0</b>	10	459905
<b>460.00</b>	<b>2 bits n. 1</b>	10	460000
<b>460.10</b>	<b>2 bits n. 2</b>	10	460109
<b>460.20</b>	<b>2 bits n. 3</b>	10	460208
<b>460.30</b>	<b>1 bits n. 4</b>	10	460307

**TITANIUM POZIDRIV BITS - 25 mm length**

<b>460.50</b>	<b>2 bits n. 0</b>	5	460505
<b>460.52</b>	<b>2 bits n. 1</b>	5	460529
<b>460.54</b>	<b>2 bits n. 2</b>	5	460543
<b>460.56</b>	<b>2 bits n. 3</b>	5	460567

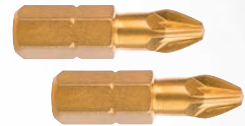
**DOUBLE FUNCTION BIT - 60 mm length**

<b>461.00</b>	slot <b>0,8 x 4 mm</b> + Phillips n. <b>1</b>	10	461007
<b>462.00</b>	slot <b>0,8 x 5 mm</b> + Phillips n. <b>2</b>	10	462004
<b>462.50</b>	slot <b>1,2 x 7,2 mm</b> + Phillips n. <b>3</b>	10	462509

**BITS ASSORTMENT**

<b>463.00</b>	<b>7 pcs: magnetic bit holder + Phillips 1 - 2 + Pozidriv 1 - 2 + slot 4 - 5 mm</b>	5	463001
<b>PG32A</b>	<b>32 pcs: quick magnetic bit holder + Phillips 1 - 2 - 3 - 4 + Pozidriv 1 - 2 - 3 - 4 + slot 3 - 4 - 5 - 6 mm + hexagonal 3 - 4 - 5 - 6 mm + T10 - T15 - T20 - T25 - T27 - T30 - T40 + Torx holed T10 - T15 - T20 - T25 - T27 - T30 - T40 + square adapter 1/4" to 1/4" hexagonal</b>	1	071046

 PG pack

 neutral pack

**BRASS WIRE WHEEL BRUSH** - shank  $\varnothing$  6 mm

<b>490.00</b>	$\varnothing$ 75 mm	<input type="checkbox"/> 10	490007
---------------	---------------------	-----------------------------	--------

**BRASS WIRE END BRUSH** - shank  $\varnothing$  6 mm

<b>492.50</b>	$\varnothing$ 25 mm	<input type="checkbox"/> 10	492506
---------------	---------------------	-----------------------------	--------

**BRASS WIRE CUP BRUSH** - shank  $\varnothing$  6 mm

<b>495.00</b>	$\varnothing$ 50 mm	<input type="checkbox"/> 10	495002
---------------	---------------------	-----------------------------	--------

**STEEL WIRE CONICAL WHEEL BRUSH** - shank  $\varnothing$  6 mm

<b>466.00</b>	$\varnothing$ 90 mm	<input type="checkbox"/> 10	466002
---------------	---------------------	-----------------------------	--------

<b>466.01</b>	20 brushes art. <b>466.00</b> bulk	<input type="checkbox"/> 1	466019
---------------	------------------------------------	----------------------------	--------

**STEEL WIRE CONICAL WHEEL BRUSH** - bore **M14**

<b>467.00</b>	$\varnothing$ 90 mm	<input type="checkbox"/> 10	467009
---------------	---------------------	-----------------------------	--------

<b>467.01</b>	20 brushes art. <b>467.00</b> bulk	<input type="checkbox"/> 1	467016
---------------	------------------------------------	----------------------------	--------

<b>468.00</b>	$\varnothing$ 120 mm	<input type="checkbox"/> 10	468006
---------------	----------------------	-----------------------------	--------

<b>468.01</b>	20 brushes art. <b>468.00</b> bulk	<input type="checkbox"/> 1	468013
---------------	------------------------------------	----------------------------	--------

<b>468.20</b>	$\varnothing$ 150 mm	<input type="checkbox"/> 5	468204
---------------	----------------------	----------------------------	--------

<b>468.30</b>	$\varnothing$ 100 mm - twisted wire	<input type="checkbox"/> 5	468303
---------------	-------------------------------------	----------------------------	--------

<b>468.35</b>	$\varnothing$ 120 mm - twisted wire	<input type="checkbox"/> 5	468358
---------------	-------------------------------------	----------------------------	--------

<b>468.40</b>	$\varnothing$ 150 mm - twisted wire	<input type="checkbox"/> 5	468402
---------------	-------------------------------------	----------------------------	--------



ref.

description

pack  
q.tyEAN13  
8011017**BRUSHING****STEEL WIRE WHEEL BRUSH - shank  $\varnothing$  6 mm**

<b>468.50</b>	$\varnothing$ 40 mm	10	468501
<b>468.51</b>	20 brushes art. <b>468.50</b> bulk	1	468518
<b>469.00</b>	$\varnothing$ 50 mm	10	469003
<b>469.01</b>	20 brushes art. <b>469.00</b> bulk	1	469010
<b>470.00</b>	$\varnothing$ 75 mm	10	470009
<b>470.01</b>	20 brushes art. <b>470.00</b> bulk	1	470016
<b>470.50</b>	$\varnothing$ 75 mm - double thickness	10	470504
<b>475.00</b>	$\varnothing$ 100 mm	10	475004
<b>475.01</b>	20 brushes art. <b>475.00</b> bulk	1	475011
<b>475.50</b>	$\varnothing$ 100 mm - double thickness	10	475509
<b>475.65</b>	$\varnothing$ 75 mm - twisted wire	5	475653
<b>475.70</b>	$\varnothing$ 100 mm - twisted wire	5	475707

**STEEL WIRE WHEEL BRUSH**

<b>485.80</b>	$\varnothing$ 75 mm - hole $\varnothing$ 13 mm	10	485805
<b>486.00</b>	$\varnothing$ 100 mm - hole $\varnothing$ 13 mm	10	486000
<b>487.00</b>	$\varnothing$ 120 mm - hole $\varnothing$ 16 mm	10	487007
<b>488.00</b>	$\varnothing$ 150 mm - hole $\varnothing$ 32/20/16 mm	10	488004
<b>489.00</b>	$\varnothing$ 200 mm - hole $\varnothing$ 32/20/16 mm thickness 20 mm	1	489001
<b>489.50</b>	$\varnothing$ 200 mm - hole $\varnothing$ 32/20/16 mm thickness 40 mm	1	489506



PG pack

neutral pack

**MINI STEEL WIRE BRUSHES** - shank  $\varnothing$  2,35 mm

<b>476.00</b>	<b>3</b> assorted mini wire brushes - $\varnothing$ 5 - 12 - 21 mm	10	476001
---------------	--	----	--------

**STEEL WIRE END BRUSH** - shank  $\varnothing$  6 mm

<b>477.00</b>	$\varnothing$ 16 mm	10	477008
<b>477.01</b>	<b>20</b> brushes art. <b>477.00</b> bulk	1	477015
<b>478.00</b>	$\varnothing$ 25 mm	10	478005
<b>478.01</b>	<b>20</b> brushes art. <b>478.00</b> bulk	1	478012

**STEEL WIRE MUSHROOM SHAPE END BRUSH** - shank  $\varnothing$  6 mm

<b>478.20</b>	$\varnothing$ 30 mm	10	478203
<b>478.40</b>	$\varnothing$ 40 mm	10	478401

**STEEL WIRE SPIRAL BRUSH** - shank  $\varnothing$  6 mm

<b>478.80</b>	$\varnothing$ 16 mm	10	478807
<b>478.90</b>	$\varnothing$ 20 mm	10	478906
<b>479.00</b>	$\varnothing$ 28 mm	10	479002
<b>479.01</b>	<b>20</b> brushes art. <b>479.00</b> bulk	1	479019
<b>479.10</b>	$\varnothing$ 38 mm	10	479101

ref.

description

pack  
q.tyEAN13  
8011017**BRUSHING****STEEL WIRE CUP BRUSH - shank  $\varnothing$  6 mm**

<b>480.00</b>	$\varnothing$ 50 mm	10	480008
<b>480.01</b>	20 brushes art. <b>480.00</b> bulk	1	480015
<b>485.00</b>	$\varnothing$ 70 mm	10	485003
<b>485.01</b>	20 brushes art. <b>485.00</b> bulk	1	485010
<b>485.20</b>	$\varnothing$ 85 mm	10	485201
<b>485.21</b>	20 brushes art. <b>485.20</b> bulk	1	485218

**STEEL WIRE CUP BRUSH - bore M14**

<b>485.30</b>	$\varnothing$ 60 mm	10	485300
<b>485.31</b>	20 brushes art. <b>485.30</b> bulk	1	485317
<b>485.40</b>	$\varnothing$ 85 mm	10	485409
<b>485.41</b>	20 brushes art. <b>485.40</b> bulk	1	485416
<b>485.50</b>	$\varnothing$ 100 mm	5	485508
<b>485.51</b>	10 brushes art. <b>485.50</b> bulk	1	485515
<b>485.60</b>	$\varnothing$ 120 mm	5	485607
<b>485.61</b>	5 brushes art. <b>485.60</b> bulk	1	485614
<b>485.65</b>	$\varnothing$ 150 mm	5	485652
<b>485.70</b>	$\varnothing$ 75 mm - twisted wire	5	485706
<b>485.75</b>	$\varnothing$ 85 mm - twisted wire	5	485751
<b>485.76</b>	$\varnothing$ 100 mm - twisted wire	1	485768
<b>485.77</b>	$\varnothing$ 120 mm - twisted wire	1	485775



PG pack

neutral pack

**ABRASIVE NYLON WIRE WHEEL BRUSH - shank  $\varnothing$  6 mm**

<b>497.05</b>	$\varnothing$ 75 mm - orange grain 80	5	497051
<b>497.10</b>	$\varnothing$ 75 mm - blue grain 150	5	497105
<b>497.15</b>	$\varnothing$ 100 mm - orange grain 80	5	497150
<b>497.20</b>	$\varnothing$ 100 mm - blue grain 150	5	497204

**ABRASIVE NYLON WIRE CUP BRUSH - shank  $\varnothing$  6 mm**

<b>497.25</b>	$\varnothing$ 50 mm - orange grain 80	5	497259
<b>497.30</b>	$\varnothing$ 50 mm - blue grain 150	5	497303
<b>497.35</b>	$\varnothing$ 70 mm - orange grain 80	5	497358
<b>497.40</b>	$\varnothing$ 70 mm - blue grain 150	5	497402

**ABRASIVE NYLON WIRE END BRUSH - shank  $\varnothing$  6 mm**

<b>497.45</b>	$\varnothing$ 25 mm - orange grain 80	5	497457
<b>497.50</b>	$\varnothing$ 25 mm - blue grain 150	5	497501

**ABRASIVE NYLON WIRE FLAP BRUSH - shank  $\varnothing$  6 mm**

<b>497.55</b>	$\varnothing$ 100 mm - orange grain 80	5	497556
<b>497.60</b>	$\varnothing$ 100 mm - blue grain 150	5	497600

ref.

description

pack  
q.tyEAN13  
8011017**BRUSHING****STEEL WIRE BRUSHES ASSORTMENT** in display box

<b>496.00</b>	<b>40</b> wire brushes:	1	496009
	<b>10</b> art. <b>469.00</b> - <b>10</b> art. <b>470.00</b>		
	<b>10</b> art. <b>480.00</b> - <b>10</b> art. <b>485.00</b>		

**ABRASIVE NYLON WIRE BRUSHES ASSORTMENT** in display box

<b>496.50</b>	<b>30</b> nylon brushes:	1	496504
	<b>3</b> each of art. <b>497.05</b> - <b>10</b> - <b>15</b> - <b>20</b> - <b>25</b> - <b>30</b> - <b>35</b> -		
	<b>40</b> - <b>45</b> - <b>50</b>		

**HAND BRUSHES ASSORTMENT** in display box

<b>496.90</b>	<b>24</b> hand brushes:	1	496900
	<b>8</b> each of art. <b>496.93</b> - <b>496.96</b> - <b>496.99</b>		



PG pack

neutral pack

**HAND BRUSH** in display box

497.00 steel wire

24

497006

**HAND BRUSH** in display box

496.99 stainless steel wire

24

496993

**HAND BRUSH** in display box

496.96 brass wire

24

496962

**HAND BRUSH** in display box

496.93 abrasive nylon wire - grain 180

24

496931



ref.

description

pack  
q.tyEAN13  
8011017**BRUSHING****MINI HAND BRUSH****496.82** steel wire

12

496825

**MINI HAND BRUSH****496.84** stainless steel wire

12

496849

**MINI HAND BRUSH****496.85** brass wire

12

496856

**MINI HAND BRUSH****496.88** nylon wire

12

496887

 PG pack neutral pack

**KIT 5 STEEL WIRE BRUSHES**

**497.02** wheel brush ø **50** mm + wheel brush ø **75** mm  
+ cup brush ø **50** mm + cup brush ø **70** mm  
+ end brush ø **16** mm

3

497020

**KIT 4 STEEL WIRE BRUSHES**

**497.04** wheel brush ø **75** mm + cup brush ø **50** mm  
+ end brush ø **25** mm + hand brush

10

497044

**KIT 4 STEEL WIRE BRUSHES**

**496.65** wheel brush ø **75** mm + cup brush ø **50** mm  
+ end brush ø **25** mm + spiral brush **28** mm

5

496658

**KIT 3 BRASS WIRE BRUSHES**

**496.70** wheel brush ø **75** mm + cup brush ø **50** mm  
+ end brush ø **25** mm

5

496702

**KIT 3 ABRASIVE NYLON WIRE BRUSHES - grain 80**

**496.75** wheel brush ø **75** mm + cup brush ø **50** mm  
+ end brush ø **25** mm

5

496757

**KIT 3 ABRASIVE NYLON WIRE BRUSHES - grain 150**

**496.80** wheel brush ø **75** mm + cup brush ø **50** mm  
+ end brush ø **25** mm

5

496801

ref.

description

pack  
q.tyEAN13  
8011017**BRUSHING**

Total items <b>15</b>		Total pcs <b>134</b>		
Professional				
10x 476.00	10x 469.00	10x 477.00	10x 478.00	10x 479.00
10x 470.00	10x 475.00	10x 480.00		
10x 485.00	10x 485.20	10x 485.40		
7x 485.30		7x 485.70		
5x 485.50		5x 485.75		

**BRUSHES DISPLAYER**

**ESPO.S1** - height **80** cm  
- width **37** cm  
- depth **32** cm

1

087450



Total items <b>8</b>		Total pcs <b>94</b>	
Professional			
10x 478.00	10x 479.00	10x 470.00	
10x 475.00	10x 485.00		
10x 485.20	10x 485.40		
24x 497.00			

**BRUSHES DISPLAYER**

**ESPO.S2** - height **70** cm  
- width **28** cm  
- depth **34** cm

1

087702

PG pack

neutral pack



**SAFETY GOGGLES**

<b>500.25</b>	even fit over your glasses - with side protections - <b>CE - EN 166</b>	1	500256
---------------	--	---	--------



**SAFETY GOGGLES**

<b>501.20</b>	with ventilation holes - directed ventilation - <b>CE - EN 166</b>	1	501208
---------------	---	---	--------



<b>501.60</b>	with ventilation valves - indirected ventilation - <b>CE - EN 166</b>	1	501604
---------------	--	---	--------



**DUST PROTECTION MASK**

<b>502.00</b>	5 disposable masks - not PPE	10	502007
<b>502.50</b>	50 disposable masks - not PPE	1	502502



**RESPIRATOR AND REPLACEMENT FILTER**

<b>504.50</b>	respirator with filter <b>A1</b> against organic vapours, paints, solvents - <b>CE - EN 140/141</b>	1	504506
<b>504.55</b>	replacement filter <b>A1</b> against organic vapours, paints, solvents - <b>CE - EN 140/141</b>	2	504551
<b>504.58</b>	replacement filter <b>P3</b> against fine dusts and aerosols - <b>CE - EN 140/143</b>	2	504582

**RESPIRATOR WITH TWO FILTERS AND REPLACEMENT FILTER**

<b>504.70</b>	respirator with <b>2</b> filters <b>A1</b> against organic vapours, paints, solvents - <b>CE - EN 140/141</b>	<b>1</b>	504704
<b>504.75</b>	replacement filter <b>A1</b> against organic vapours, paints, solvents - <b>CE - EN 140/141</b>	<b>2</b>	504759
<b>504.78</b>	replacement filter <b>P3</b> against fine dusts and aerosols - <b>CE - EN 140/143</b>	<b>2</b>	504780

**EAR PROTECTOR**

<b>505.00</b>	not PPE	<b>5</b>	505008
<b>505.20</b>	medium/high level of noise reduction <b>CE - EN 352-1</b>	<b>1</b>	505206
<b>505.40</b>	high level of noise reduction - professional <b>CE - EN 352-1</b>	<b>1</b>	505404

**EAR PLUGS**

<b>505.80</b>	<b>3</b> pairs ear plugs in polyurethane foam - <b>CE - EN 352-3</b>	<b>10</b>	505800
<b>505.83</b>	<b>5</b> pairs double layer ear plugs - high comfort - <b>CE - EN 352-3</b>	<b>10</b>	505831
<b>505.86</b>	<b>1</b> pair triple flange ear plugs with neck string - <b>CE - EN 352-2</b>	<b>10</b>	505862



EN ISO 374-5:2016

EN ISO 374-1:2016/Type B



VIRUS



JKOPT



**NITRILE GLOVES - HIGH DENSITY**  
Professional use - **CE - EN 420 - EN 374**

<b>506.10</b>	Size <b>M</b>	<b>50</b> disposable gloves: - hypo-allergenic - latex free	1	506104
<b>506.11</b>	Size <b>L</b>	- with vegetable anti sweat powders - rolled cuff	1	506111
<b>506.12</b>	Size <b>XL</b>	- ambidextrous fit - long wrist	1	506128

EN ISO 374-5:2016

EN ISO 374-1:2016/Type B



VIRUS



KPT



**MD**



**NITRILE GLOVES**  
**CE - EN 420 - EN 455 - EN 374**

<b>506.19</b>	Size <b>S</b>	<b>100</b> disposable gloves:	1	506197
<b>506.20</b>	Size <b>M</b>	- hypo-allergenic	1	506203
<b>506.21</b>	Size <b>L</b>	- latex free - powder free - rolled cuff	1	506210
<b>506.22</b>	Size <b>XL</b>	- ambidextrous fit	1	506227

**MIXER**

For cement, paints, glue and other liquids

<b>509.40</b>	∅ <b>130 x 600</b> mm - shank hex. <b>10</b>	2	509402
---------------	--	---	--------

**MIXER**

For colors, paints, glue and other liquids

<b>510.00</b>	∅ <b>60 x 350</b> mm - shank ∅ <b>6</b> mm	10	510002
---------------	--	----	--------

<b>511.00</b>	∅ <b>60 x 400</b> mm - shank hex. <b>8</b>	5	511009
---------------	--	---	--------

<b>512.00</b>	∅ <b>80 x 400</b> mm - shank hex. <b>8</b>	5	512006
---------------	--	---	--------

<b>513.00</b>	∅ <b>100 x 600</b> mm - shank hex. <b>10</b>	2	513003
---------------	--	---	--------

<b>514.00</b>	∅ <b>120 x 600</b> mm - shank hex. <b>12</b>	2	514000
---------------	--	---	--------

**MIXER**

For colors, paints, glue and other liquids

<b>514.10</b>	∅ <b>125 x 600</b> mm - shank hex. <b>10</b> - double helix	2	514109
---------------	---	---	--------

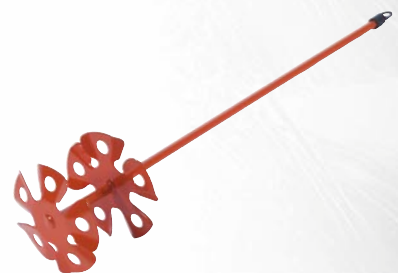

**PROFESSIONAL KNIFE**



<b>566.00</b>	automatic-safety model metal body	4	566009
<b>566.05</b>	changing of blades without tools metal body - with <b>5</b> blades included	4	566054
<b>566.11</b>	blade self loading system - <b>3</b> blades positions - with <b>5</b> blades included	2	566115



**PROFESSIONAL CUTTER - In display box**  
With metal guide blade and bi-material body



<b>566.17</b>	<b>9</b> mm blade - positive blade auto lock, blade storage lock, blade self loading system - with <b>3</b> blades included	12	566177
<b>566.18</b>	<b>18</b> mm blade - positive blade auto lock, blade storage lock, blade self loading system - with <b>3</b> blades included	12	566184
<b>566.12</b>	<b>25</b> mm blade	12	566122

**CUTTER**



<b>566.20</b>	<b>9</b> mm blade - metal body	24	566207
<b>566.23</b>	<b>9</b> mm blade - ABS body	24	566238
<b>566.25</b>	<b>9</b> mm blade - metal guide blade	24	566252



ref.

description

pack  
q.tyEAN13  
8011017**KNIVES****CUTTER**

With retractable snap-off blade and safety stop

<b>566.30</b>	9 mm blade - ABS body	24	566306
<b>566.40</b>	18 mm blade - ABS body	24	566405
<b>566.50</b>	18 mm blade - metal guide blade	24	566504
<b>566.60</b>	18 mm blade - metal guide blade	24	566603

**SCRAPER**

<b>567.00</b>	with retractable blade 60 mm	24	567006
---------------	------------------------------	----	--------

**REPLACEMENT BLADES**

<b>568.00</b>	5 medium heavy-duty blades 52 mm	12	568003
<b>568.10</b>	5 large heavy-duty blades 60 mm	12	568102
<b>568.20</b>	5 hook blades 49 mm	12	568201
<b>568.30</b>	10 snap-off 9 mm blades	12	568300
<b>568.40</b>	10 snap-off 18 mm blades	12	568409
<b>568.50</b>	5 snap-off 25 mm blades	12	568508

**GLASS CUTTER** with hard metal wheel

<b>569.00</b>	≠ 3-6 mm	5	569000
---------------	----------	---	--------



PG pack

neutral pack



## WOOD CARVING TOOLS

<b>570.00</b>	5 carving tools assorted shapes: double bevel, rounded, pointed, hollow, bevelled	<input checked="" type="checkbox"/>	2	570006
---------------	---	-------------------------------------	---	--------



## WOOD CARVING TOOLS

<b>572.00</b>	6 carving tools assorted shapes: double bevel, rounded, pointed, hollow, bevelled, carver	<input checked="" type="checkbox"/>	2	572000
---------------	---	-------------------------------------	---	--------

## FLAT CHISEL wooden handle



<b>575.00</b>	6 mm	<input checked="" type="checkbox"/>	5	575001
<b>576.00</b>	8 mm	<input checked="" type="checkbox"/>	5	576008
<b>577.00</b>	10 mm	<input checked="" type="checkbox"/>	5	577005
<b>578.00</b>	12 mm	<input checked="" type="checkbox"/>	5	578002
<b>579.00</b>	14 mm	<input checked="" type="checkbox"/>	5	579009
<b>580.00</b>	16 mm	<input checked="" type="checkbox"/>	5	580005
<b>581.00</b>	18 mm	<input checked="" type="checkbox"/>	5	581002
<b>582.00</b>	20 mm	<input checked="" type="checkbox"/>	5	582009
<b>583.00</b>	25 mm	<input checked="" type="checkbox"/>	5	583006
<b>584.00</b>	30 mm	<input checked="" type="checkbox"/>	5	584003
<b>585.00</b>	32 mm	<input checked="" type="checkbox"/>	5	585000
<b>586.00</b>	38 mm	<input checked="" type="checkbox"/>	5	586007

## WOOD GIMLET



<b>590.00</b>	∅ 2 mm	<input checked="" type="checkbox"/>	10	590004
<b>591.00</b>	∅ 3 mm	<input checked="" type="checkbox"/>	10	591001
<b>592.00</b>	∅ 4 mm	<input checked="" type="checkbox"/>	10	592008
<b>593.00</b>	∅ 5 mm	<input checked="" type="checkbox"/>	10	593005
<b>594.00</b>	∅ 6 mm	<input checked="" type="checkbox"/>	10	594002
<b>597.00</b>	3 wood gimlets ∅ 2 - 3 - 4 mm	<input checked="" type="checkbox"/>	10	597003

ref.

description

pack  
q.tyEAN13  
8011017**WOOD TOOLS****WOODEN AND REBATE PLANE**

Smoothing steel blade

<b>624.00</b>	<b>36 mm</b>	1	624006
<b>625.00</b>	<b>45 mm - double steel blade</b>	1	625003
<b>626.00</b>	<b>48 mm - double steel blade</b>	1	626000

**WOODEN AND REBATE PLANE**

Smoothing steel blade

<b>628.00</b>	<b>24 mm</b>	1	628004
<b>629.00</b>	<b>27 mm</b>	1	629001

**HARD METAL PLANER BLADES**

ref.	description	suitable with:	q.ty	EAN13 8011017
<b>629.85</b>	<b>2 blades 75,5 x 5,5 x 1,1 mm</b>	AEG - B&D - Bosch - Festo - Haffner - Holz Her - Kress - Mafell - Metabo - Scheer - Skil	5	629858
<b>629.87</b>	<b>2 blades 80,5 x 5,9 x 1,1 mm</b>	Elu - B&D	5	629872
<b>629.89</b>	<b>2 blades 82,0 x 5,5 x 1,1 mm</b>	AEG - B&D - Bosch - Fein - Felisatti - Festo - Haffner - Hitachi - Holz Her - Mafell - Makita - Metabo - Skil	5	629896



PG pack

neutral pack



**TACKER**

<b>601.00</b>	plastic body for home and hobby accepts staples <b>4 - 6 - 8</b> mm	<b>1</b>	601007
---------------	--	----------	--------



**TACKER**

<b>604.00</b>	metal body for home and work - adjustable force accepts staples from <b>4</b> to <b>14</b> mm	<b>1</b>	604008
---------------	--	----------	--------

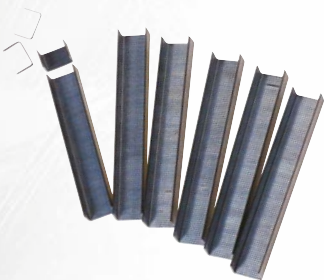

**STAPLES**

<b>607.35</b>	<b>1000</b> staples <b>6</b> mm	<b>10</b>	607351
<b>607.45</b>	<b>1000</b> staples <b>8</b> mm	<b>10</b>	607450
<b>607.55</b>	<b>1000</b> staples <b>10</b> mm	<b>10</b>	607559
<b>607.65</b>	<b>1000</b> staples <b>12</b> mm	<b>10</b>	607658
<b>607.75</b>	<b>1000</b> staples <b>14</b> mm	<b>10</b>	607757

ref.

description

pack  
q.tyEAN13  
8011017**MEASURING****TAPE RULE MEASURE**

Abs body, nylon metal tape with double stop and automatic rewind

<b>611.10</b>	<b>3 m - 16 mm tape - €€</b>	12	611105
<b>611.20</b>	<b>5 m - 19 mm tape - €€</b>	6	611204
<b>611.30</b>	<b>8 m - 25 mm tape - €€</b>	4	611303

**TAPE RULE MEASURES** in display box

<b>611.25</b>	<b>12 tape rule measures 5 m art. 611.20 - €€</b>	1	611259
---------------	---	---	--------

 PG pack

 neutral pack

## CARPENTER PENCIL

649.00	180 mm	<input type="checkbox"/>	144	009407
649.06	6 pencils 180 mm	<input type="checkbox"/>	5	649061

## DOWELMATE DOWELLING KIT

650.00	including 1 dowelling jig - 3 spacers - assorted wooden dowels $\varnothing$ 6 - 8 - 10 mm	<input type="checkbox"/>	1	650005
--------	--	--------------------------	---	--------

## FLUTED WOODEN DOWELS

655.00	100 wooden dowels $\varnothing$ 6 x 30 mm	<input type="checkbox"/>	10	655000
655.05	1000 wooden dowels $\varnothing$ 6 x 30 mm	<input type="checkbox"/>	1	655055
660.00	60 wooden dowels $\varnothing$ 8 x 35 mm	<input type="checkbox"/>	10	660004
660.05	1000 wooden dowels $\varnothing$ 8 x 35 mm	<input type="checkbox"/>	1	660059
662.00	60 wooden dowels $\varnothing$ 8 x 40 mm	<input type="checkbox"/>	10	662008
662.05	1000 wooden dowels $\varnothing$ 8 x 40 mm	<input type="checkbox"/>	1	662053
665.00	40 wooden dowels $\varnothing$ 10 x 40 mm	<input type="checkbox"/>	10	665009
665.05	1000 wooden dowels $\varnothing$ 10 x 40 mm	<input type="checkbox"/>	1	665054
666.00	30 wooden dowels $\varnothing$ 12 x 40 mm	<input type="checkbox"/>	10	666006
666.05	500 wooden dowels $\varnothing$ 12 x 40 mm	<input type="checkbox"/>	1	666051

## EXTRA-LONG FLUTED WOODEN DOWELS

668.00	100 wooden dowels $\varnothing$ 6 x 1000 mm	<input type="checkbox"/>	1	668000
668.10	100 wooden dowels $\varnothing$ 8 x 1000 mm	<input type="checkbox"/>	1	668109
668.20	100 wooden dowels $\varnothing$ 10 x 1000 mm	<input type="checkbox"/>	1	668208
668.30	50 wooden dowels $\varnothing$ 12 x 1000 mm	<input type="checkbox"/>	1	668307
668.40	40 wooden dowels $\varnothing$ 14 x 1000 mm	<input type="checkbox"/>	1	668406
668.50	40 wooden dowels $\varnothing$ 16 x 1000 mm	<input type="checkbox"/>	1	668505

ref.

description

pack  
q.tyEAN13  
8011017**WOOD JOINTING****DEPTH STOPS**

<b>620.00</b>	<b>3</b> depth stops $\varnothing$ <b>6 - 8 - 10</b> mm	10	620008
<b>620.10</b>	<b>1</b> depth stop $\varnothing$ <b>12</b> mm	10	620107
<b>620.20</b>	<b>1</b> depth stop $\varnothing$ <b>14</b> mm	10	620206

**CENTRE POINTS**

<b>670.00</b>	<b>4</b> centre points $\varnothing$ <b>6</b> mm	10	670003
<b>675.00</b>	<b>4</b> centre points $\varnothing$ <b>8</b> mm	10	675008
<b>680.00</b>	<b>4</b> centre points $\varnothing$ <b>10</b> mm	10	680002
<b>680.10</b>	<b>4</b> centre points $\varnothing$ <b>12</b> mm	10	680101
<b>680.20</b>	<b>2</b> centre points $\varnothing$ <b>14</b> mm	10	680200

**DOWELLING KITS**

<b>681.00</b>	complete with drill $\varnothing$ <b>6</b> mm - depth stop - <b>4</b> centre points - <b>25</b> wooden dowels $\varnothing$ <b>6</b> mm	5	681009
<b>682.00</b>	complete with drill $\varnothing$ <b>8</b> mm - depth stop - <b>4</b> centre points - <b>25</b> wooden dowels $\varnothing$ <b>8</b> mm	5	682006
<b>683.00</b>	complete with drill $\varnothing$ <b>10</b> mm - depth stop - <b>4</b> centre points - <b>20</b> wooden dowels $\varnothing$ <b>10</b> mm	5	683003

**WOODEN JOINTING BISCUITS**

<b>669.00</b>	<b>50</b> wooden biscuits type <b>0</b> - <b>47 x 15 x 4</b> mm	10	669007
<b>669.05</b>	<b>1000</b> wooden biscuits type <b>0</b> - <b>47 x 15 x 4</b> mm	1	669052
<b>669.10</b>	<b>50</b> wooden biscuits type <b>10</b> - <b>53 x 19 x 4</b> mm	10	669106
<b>669.15</b>	<b>1000</b> wooden biscuits type <b>10</b> - <b>53 x 19 x 4</b> mm	1	669151
<b>669.20</b>	<b>50</b> wooden biscuits type <b>20</b> - <b>59 x 23 x 4</b> mm	10	669205
<b>669.25</b>	<b>1000</b> wooden biscuits type <b>20</b> - <b>59 x 23 x 4</b> mm	1	669250



PG pack

neutral pack

**JIGSAW BLADES - BLACK & DECKER - SKIL FITTING**  
**HSS - for metal**

**HSS** HIGH SPEED STEEL



<b>684.00</b>	<b>3 blades - 76 mm - coarse cutting</b>	10	684000
<b>685.00</b>	<b>3 blades - 76 mm - medium cutting</b>	10	685007
<b>686.00</b>	<b>3 blades - 76 mm - fine cutting</b>	10	686004
<b>686.50</b>	<b>3 blades - 100 mm - medium cutting</b>	10	686509

**CV - for wood**

**CV** CHROME VANADIUM

**CV** CHROME VANADIUM

**CV** CHROME VANADIUM

<b>687.00</b>	<b>3 blades - 100 mm - coarse cutting</b>	10	687001
<b>688.00</b>	<b>3 blades - 100 mm - medium cutting</b>	10	688008
<b>689.00</b>	<b>3 blades - 76 mm - fine cutting</b>	10	689005
<b>689.10</b>	<b>3 blades - 100 mm - coarse cutting - grounded blade</b>	10	689104
<b>689.20</b>	<b>3 blades - 100 mm - medium cutting - grounded blade</b>	10	689203
<b>689.50</b>	<b>3 blades - 116 mm - medium cutting</b>	10	689500
<b>720.00</b>	<b>3 blades - 100 mm - medium cutting - for cutting curves</b>	10	720005

**HARD METAL - for glass, tiles, bricks and plastic laminates**

**HM** HARD METAL

<b>724.00</b>	<b>1 blade - 76 mm</b>	5	724003
---------------	------------------------	---	--------



**KIT 10 JIGSAW BLADES - BLACK & DECKER - SKIL FITTING**

<b>720.90</b>	<b>3 CV blades coarse cutting for wood + 3 CV blades medium cutting for wood + 2 CV blades cutting curves for wood + 2 HSS blades fine cutting for metal</b>	3	720906
---------------	--	---	--------

PG pack

neutral pack



ref.

description

pack  
q.tyEAN13  
8011017**JIGSAW BLADES****JIGSAW BLADES - WIDE BOSCH FITTING****HSS - for metal**

<b>694.00</b>	<b>3</b> blades - <b>76</b> mm - <b>coarse</b> cutting	10	694009
<b>695.00</b>	<b>3</b> blades - <b>76</b> mm - <b>medium</b> cutting	10	695006
<b>696.00</b>	<b>3</b> blades - <b>76</b> mm - <b>fine</b> cutting	10	696003
<b>696.50</b>	<b>3</b> blades - <b>100</b> mm - <b>medium</b> cutting - <b>80</b> mm length	10	696508

**CV - for wood**

<b>697.00</b>	<b>3</b> blades - <b>100</b> mm - <b>coarse</b> cutting	10	697000
<b>698.00</b>	<b>3</b> blades - <b>100</b> mm - <b>medium</b> cutting	10	698007
<b>699.00</b>	<b>3</b> blades - <b>76</b> mm - <b>fine</b> cutting	10	699004
<b>699.10</b>	<b>3</b> blades - <b>100</b> mm - <b>coarse</b> cutting - grounded blade	10	699103
<b>699.20</b>	<b>3</b> blades - <b>100</b> mm - <b>medium</b> cutting - grounded blade	10	699202
<b>699.50</b>	<b>3</b> blades - <b>116</b> mm - <b>medium</b> cutting	10	699509
<b>699.60</b>	<b>2</b> blades - <b>250</b> mm - <b>medium</b> cutting - for insulating materials and styrofoam	10	087399
<b>721.00</b>	<b>3</b> blades - <b>76</b> mm - <b>medium</b> cutting - for cutting curves	10	721002

**HARD METAL - for glass, tiles, bricks and plastic laminates**

<b>725.00</b>	<b>1</b> blade - <b>76</b> mm	5	725000
---------------	-------------------------------	---	--------

**KIT 10 JIGSAW BLADES - WIDE BOSCH FITTING**

<b>721.90</b>	<b>3</b> CV blades coarse cutting for wood + <b>3</b> CV blades medium cutting for wood + <b>2</b> CV blades cutting curves for wood + <b>2</b> HSS blades fine cutting for metal	3	721903
---------------	---	---	--------



PG pack

neutral pack

## JIGSAW BLADES - MAKITA FITTING

### HSS - for metal

<b>714.00</b>	<b>3 blades - 80 mm - coarse cutting</b>	10	714004
<b>715.00</b>	<b>3 blades - 80 mm - medium cutting</b>	10	715001
<b>716.00</b>	<b>3 blades - 80 mm - fine cutting</b>	10	716008

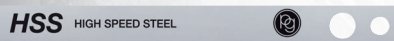

### CV - for wood

<b>717.00</b>	<b>3 blades - 100 mm - coarse cutting</b>	10	717005
<b>718.00</b>	<b>3 blades - 80 mm - medium cutting</b>	10	718002
<b>722.00</b>	<b>3 blades - 76 mm - medium cutting - for cutting curves</b>	10	722009



## JIGSAW BLADES - NARROW BOSCH FITTING

### HSS - for metal

<b>704.00</b>	<b>3 blades - 85 mm - coarse cutting</b>	10	704005
<b>705.00</b>	<b>3 blades - 85 mm - medium cutting</b>	10	705002
<b>706.00</b>	<b>3 blades - 85 mm - fine cutting</b>	10	706009



### CV - for wood

<b>707.00</b>	<b>3 blades - 90 mm - coarse cutting</b>	10	707006
<b>708.00</b>	<b>3 blades - 90 mm - medium cutting</b>	10	708003



ref.

description

pack  
q.tyEAN13  
8011017**HOLE SAWS****HOLE SAW**

For wood, plasterboards, plastic

<b>730.00</b>	with <b>7</b> blades from $\varnothing$ <b>25</b> mm to $\varnothing$ <b>62</b> mm height <b>25</b> mm	<input type="checkbox"/>	10	730004
<b>732.00</b>	with <b>7</b> blades from $\varnothing$ <b>25</b> mm to $\varnothing$ <b>62</b> mm height <b>50</b> mm	<input type="checkbox"/>	10	732008
<b>735.00</b>	with <b>5</b> blades from $\varnothing$ <b>60</b> mm to $\varnothing$ <b>95</b> mm height <b>40</b> mm	<input type="checkbox"/>	5	735009

**CIRCULAR TILE CUTTER**

With pilot drill and carbide tipped cutter

<b>217.00</b>	from $\varnothing$ <b>30</b> mm to $\varnothing$ <b>100</b> mm - <b>450</b> RPM	<input type="checkbox"/>	1	217000
<b>217.10</b>	cutting tool for art. <b>217.00</b>	<input type="checkbox"/>	1	217109

**BIMETAL HOLE SAW ARBOR**

<b>13.780</b>	$\varnothing$ <b>14/30</b> mm - shank $\varnothing$ <b>6,35</b> mm	<input type="checkbox"/>	1	137803
<b>13.785</b>	$\varnothing$ <b>32/152</b> mm - shank $\varnothing$ <b>6,35</b> mm	<input type="checkbox"/>	1	137858
<b>13.790</b>	$\varnothing$ <b>14/30</b> mm - shank hex. <b>12</b> mm	<input type="checkbox"/>	1	137902
<b>13.795</b>	$\varnothing$ <b>32/152</b> mm - shank hex. <b>12</b> mm	<input type="checkbox"/>	1	137957

**REPLACEMENT DRILL FOR BIMETAL ARBOR**

<b>13.800</b>	length <b>115</b> mm	<input type="checkbox"/>	1	138008
<b>13.805</b>	length <b>70</b> mm	<input type="checkbox"/>	1	138053

 PG pack neutral pack

## BIMETAL HOLE SAW

13.500	∅ 14 mm	1	135007
13.505	∅ 16 mm	1	135052
13.510	∅ 17 mm	1	135106
13.515	∅ 19 mm	1	135151
13.520	∅ 20 mm	1	135205
13.525	∅ 21 mm	1	135250
13.530	∅ 22 mm	1	135304
13.535	∅ 24 mm	1	135359
13.540	∅ 25 mm	1	135403
13.545	∅ 27 mm	1	135458
13.550	∅ 29 mm	1	135502
13.555	∅ 30 mm	1	135557
13.560	∅ 32 mm	1	135601
13.565	∅ 33 mm	1	135656
13.570	∅ 35 mm	1	135700
13.575	∅ 37 mm	1	135755
13.580	∅ 38 mm	1	135809
13.585	∅ 40 mm	1	135854
13.590	∅ 41 mm	1	135908
13.595	∅ 43 mm	1	135953
13.600	∅ 44 mm	1	136004
13.605	∅ 46 mm	1	136059
13.610	∅ 48 mm	1	136103
13.615	∅ 51 mm	1	136158
13.620	∅ 52 mm	1	136202
13.625	∅ 54 mm	1	136257
13.630	∅ 57 mm	1	136301
13.635	∅ 59 mm	1	136356
13.640	∅ 60 mm	1	136400
13.645	∅ 64 mm	1	136455
13.650	∅ 65 mm	1	136509
13.655	∅ 67 mm	1	136554
13.660	∅ 70 mm	1	136608
13.665	∅ 73 mm	1	136653
13.670	∅ 76 mm	1	136707
13.675	∅ 79 mm	1	136752
13.680	∅ 83 mm	1	136806
13.685	∅ 86 mm	1	136851
13.690	∅ 89 mm	1	136905
13.695	∅ 92 mm	1	136950
13.700	∅ 95 mm	1	137001
13.705	∅ 98 mm	1	137056
13.710	∅ 102 mm	1	137100
13.715	∅ 105 mm	1	137155
13.720	∅ 108 mm	1	137209
13.725	∅ 111 mm	1	137254
13.730	∅ 114 mm	1	137308
13.735	∅ 121 mm	1	137353
13.740	∅ 127 mm	1	137407
13.745	∅ 140 mm	1	137452
13.750	∅ 152 mm	1	137506



**CV CIRCULAR SAW BLADE**

ø mm		n. teeth	RPM	ref.	q.ty	EAN13 8011017
est.	bore					
<b>125</b>	<b>20</b>	<b>24</b>	<b>7000</b>	<b>740.00</b>	<b>5</b>	740003
<b>125</b>	<b>20</b>	<b>80</b>	<b>7000</b>	<b>745.00</b>	<b>5</b>	745008
<b>150</b>	<b>20</b>	<b>24</b>	<b>7000</b>	<b>750.00</b>	<b>5</b>	750002
<b>150</b>	<b>20</b>	<b>80</b>	<b>7000</b>	<b>755.00</b>	<b>5</b>	755007

With **2** bushes for adapting the bore: **20/13** mm and **20/16** mm



**CARBIDE TIPPED CIRCULAR SAW BLADE  
ALTERNATE TEETH**

ø mm		n. teeth	suitable with:	RPM	ref.	q.ty	EAN13 8011017
est.	bore						
<b>125</b>	<b>20</b>	<b>18</b>	Bosch - Festo - Haffner - Hitachi - Mafell - Metabo - Ulmia	<b>13000</b>	<b>756.02</b>	<b>1</b>	756028
<b>150</b>	<b>20</b>	<b>20</b>	AEG - B&D - Bosch - Elu - Fein - Hitachi - Kress - Mafell -	<b>13000</b>	<b>756.10</b>	<b>1</b>	756103
<b>150</b>	<b>30</b>	<b>36</b>	Metabo - Peugeot - Scheer - Skil - Wegoma	<b>13000</b>	<b>756.12</b>	<b>1</b>	756127
<b>160</b>	<b>20</b>	<b>24</b>	AEG - B&D - Bosch - Einhell - Fein - Festo - Haffner - Hitachi	<b>9500</b>	<b>756.14</b>	<b>1</b>	756141
<b>160</b>	<b>20</b>	<b>36</b>	- Holz Her - Kress - Mafell - Makita - Narex - Peugeot - Protool - Rockwell - Ryobi - Scheer - Skil - Ulmia	<b>9500</b>	<b>756.16</b>	<b>1</b>	756165
<b>170</b>	<b>30</b>	<b>18</b>	Bosch - Elu - Festo - Haffner - Hitachi - Holz Her - Mafell -	<b>9500</b>	<b>756.18</b>	<b>1</b>	756189
<b>170</b>	<b>30</b>	<b>36</b>	Makita - Metabo - Skil	<b>9500</b>	<b>756.20</b>	<b>1</b>	756202
<b>180</b>	<b>30</b>	<b>36</b>	B&D - Bosch - Elu - Festo - Haffner - Hitachi - Holz Her - Mafell - Makita - Metabo - Peugeot - Ryobi - Skil	<b>9500</b>	<b>756.24</b>	<b>1</b>	756240
<b>190</b>	<b>30</b>	<b>42</b>	AEG - B&D - Bosch - DeWalt - Elu - Festo - Hitachi - Holz Her - Kress - Mafell - Makita - Metabo - Protool - Scheer - Skil - Stayer	<b>9500</b>	<b>756.30</b>	<b>1</b>	756301
<b>200</b>	<b>30</b>	<b>42</b>	AEG - B&D - Bosch - Festo - Haffner - Hanning - Holz Her - Kity - Mafell - Makita - Ryobi - Scheer - Ulmia	<b>9500</b>	<b>756.32</b>	<b>1</b>	756325
<b>210</b>	<b>30</b>	<b>30</b>	AEG - B&D - Bosch - Elektra Beckum - Elu - Fein - Haffner -	<b>9500</b>	<b>756.38</b>	<b>1</b>	756387
<b>210</b>	<b>30</b>	<b>42</b>	Hitachi - Holz Her - Mafell - Makita - Metabo - Skil - Stayer	<b>9500</b>	<b>756.40</b>	<b>1</b>	756400
<b>230</b>	<b>30</b>	<b>20</b>	AEG - B&D - Bosch - Festo - Haffner - Holz Her - Mafell -	<b>9500</b>	<b>756.42</b>	<b>1</b>	756424
<b>230</b>	<b>30</b>	<b>34</b>	Peugeot - Scheer - Skil - Stayer	<b>9500</b>	<b>756.44</b>	<b>1</b>	756448
<b>250</b>	<b>30</b>	<b>24</b>	Elektra Beckum - Elu - Mafell - Metabo	<b>8000</b>	<b>756.48</b>	<b>1</b>	756486
<b>250</b>	<b>30</b>	<b>48</b>		<b>8000</b>	<b>756.50</b>	<b>1</b>	756509
<b>250</b>	<b>30</b>	<b>60</b>		<b>8000</b>	<b>756.52</b>	<b>1</b>	756523
<b>300</b>	<b>30</b>	<b>72</b>	Elektra Beckum - Elu	<b>4000</b>	<b>756.56</b>	<b>1</b>	756561
<b>300</b>	<b>30</b>	<b>96</b>		<b>4000</b>	<b>756.58</b>	<b>1</b>	756585
<b>350</b>	<b>30</b>	<b>84</b>	Festo	<b>4000</b>	<b>756.60</b>	<b>1</b>	756608
<b>350</b>	<b>30</b>	<b>108</b>		<b>4000</b>	<b>756.62</b>	<b>1</b>	756622

**KEYLESS CHUCK**

Male threaded



<b>760.00</b>	<b>3/8" x 24 - ø 10 mm</b> for Black & Decker	1	760001
---------------	--	---	--------

**KEYLESS CHUCK**

Female threaded



<b>762.00</b>	<b>3/8" x 24 - ø 10 mm</b> for Skil, Metabo, Makita, Wolf	1	762005
<b>764.00</b>	<b>3/8" x 24 - ø 13 mm</b> for Skil, Metabo, Makita, Wolf	1	764009
<b>766.00</b>	<b>1/2" x 20 - ø 10 mm</b> for Atlas Copco, Bosch, Fein, Kress, Metabo	1	766003
<b>768.00</b>	<b>1/2" x 20 - ø 13 mm</b> for Atlas Copco, Bosch, Fein, Kress, Metabo	1	768007

**KEYLESS CHUCK for reversing power tools**

Male threaded



<b>773.00</b>	<b>3/8" x 24 - ø 10 mm</b> for Black & Decker	1	773001
---------------	--	---	--------

**KEYLESS CHUCK for reversing power tools**

Female threaded



<b>774.00</b>	<b>3/8" x 24 - ø 10 mm</b> for Skil, Metabo, Makita, Wolf	1	774008
<b>774.50</b>	<b>3/8" x 24 - ø 13 mm</b> for Skil, Metabo, Makita, Wolf	1	774503
<b>775.00</b>	<b>1/2" x 20 - ø 10 mm</b> for Atlas Copco, Bosch, Fein, Kress, Metabo	1	775005
<b>775.50</b>	<b>1/2" x 20 - ø 13 mm - metal body -</b> <b>SUITABLE ALSO FOR HAMMER DRILLS</b> for Atlas Copco, Bosch, Fein, Kress, Metabo	1	775500
<b>775.60</b>	<b>1/2" x 20 - ø 13 mm</b> for Atlas Copco, Bosch, Fein, Kress, Metabo	1	775609

**KEYLESS CHUCK**

SDS PLUS shank

<b>775.51</b>	<b>ø 13 mm - metal body -</b> <b>SUITABLE ALSO FOR HAMMER DRILLS</b>	1	775517
<b>775.61</b>	<b>ø 13 mm</b>	1	775616

ref.

description

pack  
q.tyEAN13  
8011017**CHUCKS****CHUCK WITH KEY**

Male threaded

<b>780.00</b>	<b>3/8" x 24 - ø 10 mm</b> for Black & Decker	1	780009
<b>781.00</b>	<b>3/8" x 24 - ø 13 mm</b> for Black & Decker	1	781006

**CHUCK WITH KEY**

Female threaded

<b>783.00</b>	<b>3/8" x 24 - ø 10 mm</b> for Skil, Metabo, Makita, Wolf ( <b>38 mm</b> )	1	783000
<b>784.00</b>	<b>3/8" x 24 - ø 13 mm</b> for Skil, Metabo, Makita, Wolf ( <b>38 mm</b> )	1	784007
<b>786.00</b>	<b>1/2" x 20 - ø 10 mm</b> for Atlas Copco, Bosch, Fein, Kress, Metabo ( <b>43 mm</b> )	1	786001
<b>787.00</b>	<b>1/2" x 20 - ø 13 mm</b> for Atlas Copco, Bosch, Fein, Kress, Metabo ( <b>43 mm</b> )	1	787008

**CHUCK WITH KEY**

SDS PLUS shank

<b>787.01</b>	<b>ø 13 mm</b>	1	787015
---------------	----------------	---	--------

**CHUCK WITH KEY**

Exagonal shank

<b>788.00</b>	<b>ø 10 mm</b>	1	788005
---------------	----------------	---	--------

**DRILL CHUCK**

Exagonal shank

<b>788.50</b>	<b>ø 0,5-6,5 mm</b>	5	788500
---------------	---------------------	---	--------

 PG pack

 neutral pack

**CHUCK ADAPTOR**

<b>789.00</b>	<b>SDS PLUS</b> fitting 1/2" x 20	5	789002
<b>789.10</b>	<b>M6</b> left hand locking screw for chucks	1	789101
<b>789.50</b>	male 3/8" - male 1/2"	1	789507
<b>789.60</b>	male 3/8" - male 3/8"	1	789606
<b>789.70</b>	male 1/2" - female 3/8"	1	789705

**DRILL CHUCK KEY**

<b>790.00</b>	<b>10 mm</b> - for Black & Decker	10	790008
<b>791.00</b>	<b>13 mm</b> - for Black & Decker	10	791005
<b>792.00</b>	<b>13 mm</b> - universal	10	792002
<b>793.00</b>	<b>16 mm</b> - universal	5	793009
<b>794.00</b>	universal	5	794006

**FLEXIBLE SHAFT**

With ball bearings



<b>550.00</b>	<b>90 cm</b> length - chuck $\varnothing$ 8 mm - shank hex. 1/4" 4000 RPM - $\text{CE}$	1	550008
<b>560.00</b>	<b>130 cm</b> length - chuck $\varnothing$ 8 mm - shank hex. 1/4" 8000 RPM - $\text{CE}$	1	560007

**REPLACEMENT CHUCK**

<b>555.08</b>	$\varnothing$ 8 mm	1	555089
---------------	--------------------	---	--------



ref.

description

pack  
q.tyEAN13  
8011017**TOOLS AND  
ACCESSORIES****MARKING PEN WITH CARBIDE TIP**

To mark on metal, glass and tiles

**598.50** 150 mm

5

598505

Output	<b>20 Watt</b>
Voltage	<b>230 V / 50 Hz</b>
Cable length	<b>1,2 m</b>
Weight	<b>110 g</b>

**GLUE GUN**

Nozzle with heat protection, drip block. Mechanical aid. Shockproof plastic casing. For bonding paper, plastic, wood, ceramic, textiles

**599.00** with 2 glue sticks ø 7 mm

1

599007

Output	<b>40 Watt</b>
Voltage	<b>230 V / 50 Hz</b>
Cable length	<b>1,2 m</b>
Weight	<b>170 g</b>

**GLUE GUN**

Nozzle with heat protection, drip block. Mechanical aid. Shockproof plastic casing. For bonding paper, plastic, wood, ceramic, textiles

**599.20** with 2 glue sticks ø 11 mm

1

599205

Output	<b>40 Watt</b>
Voltage	<b>230 V / 50 Hz</b>
Cable length	<b>1,2 m</b>
Weight	<b>170 g</b>

**HOT MELT GLUE STICKS****600.00** 12 sticks ø 7 mm - lenght 100 mm

10

600000

**600.20** 12 sticks ø 11 mm - lenght 100 mm

10

600208



PG pack

neutral pack



**DRILL POWERED PUMP - C€**

Do not use to pump any toxic, corrosive, explosive or combustible materials.  
Do not use to pump water intended for drinking



<b>890.00</b>	- flow rate <b>2500</b> litres/hour	<input type="text" value="5"/>	890005
	- suction height <b>2,5</b> m		
	- pumping height <b>10</b> m		
	- dry running <b>30"</b>		
	- for pipes <b>1/2"</b>		
	- shank $\varnothing$ <b>8</b> mm		
	- <b>3000</b> RPM		



**HAND DRILL**

<b>921.00</b>	$\varnothing$ <b>6</b> mm chuck plastic handle - with bit storage	<input type="text" value="5"/>	921006
<b>928.00</b>	$\varnothing$ <b>13</b> mm chuck two speeds - with support	<input type="text" value="1"/>	928005





**REPLACEMENT CHUCK FOR HAND DRILL**

<b>930.00</b>	$\varnothing$ <b>6</b> mm	<input type="text" value="1"/>	930008
<b>936.00</b>	$\varnothing$ <b>13</b> mm	<input type="text" value="1"/>	936000



**CV KEY WRENCHES**

<b>946.00</b>	<b>8</b> key wrenches for hexagonal screws <b>1,5 - 2 - 2,5 - 3 - 4 - 5 - 5,5 - 6</b>		<input type="text" value="10"/>	946009
<b>946.50</b>	<b>10</b> key wrenches for hexagonal screws <b>1,5 - 2 - 2,5 - 3 - 4 - 5 - 5,5 - 6 - 8 - 10</b>		<input type="text" value="10"/>	946504

## CARPENTER CLAMP

<b>948.00</b>	max opening <b>150</b> mm	6	948003
<b>948.10</b>	max opening <b>200</b> mm	6	948102
<b>948.20</b>	max opening <b>250</b> mm	6	948201
<b>948.30</b>	max opening <b>300</b> mm	6	948300
<b>948.40</b>	max opening <b>400</b> mm	4	948409
<b>948.50</b>	max opening <b>500</b> mm	4	948508
<b>948.60</b>	max opening <b>600</b> mm	4	948607
<b>948.65</b>	max opening <b>700</b> mm	2	948652
<b>948.70</b>	max opening <b>800</b> mm	2	948706
<b>948.80</b>	max opening <b>1000</b> mm	2	948805
<b>948.82</b>	max opening <b>1200</b> mm	2	948829
<b>948.84</b>	max opening <b>1500</b> mm	2	948843



## ONE HAND CLAMP

<b>948.93</b>	max opening <b>150</b> mm	4	948935
<b>948.95</b>	max opening <b>300</b> mm	4	948959
<b>948.97</b>	max opening <b>450</b> mm	4	948973



## ALUMINIUM "C" CLAMP

With quick adjustment and steel spindle

<b>949.00</b>	<b>80 x 65</b> mm	1	949000
<b>949.10</b>	<b>105 x 75</b> mm	1	949109
<b>949.20</b>	<b>160 x 75</b> mm	1	949208





**CLAMP**

<b>949.50</b>	max opening <b>50</b> mm	5	949505
<b>949.60</b>	max opening <b>75</b> mm	5	949604
<b>949.70</b>	max opening <b>100</b> mm	5	949703



**CLAMP**

<b>951.00</b>	max opening <b>25</b> mm	10	951003
<b>952.00</b>	max opening <b>50</b> mm	10	952000
<b>953.00</b>	max opening <b>75</b> mm	10	953007



**QUICK PRESS VICE** in die-cast aluminium with quick adjuster and steel jaws to clamp round material

<b>954.00</b>	max opening <b>65</b> mm	1	954004
---------------	--------------------------	---	--------

**MOBILE CLAMP**

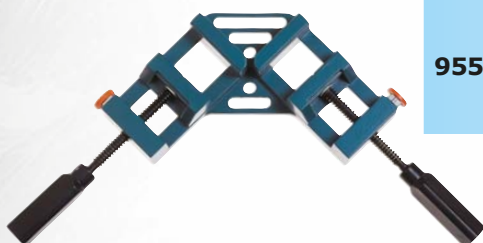

<b>955.00</b>	mobile clamp for <b>90°</b> corner joints saw guide for <b>45°</b> and work bench vice	1	955001
---------------	--	---	--------



**CORNER CLAMP**

<b>956.00</b>	max opening <b>75</b> mm	5	956008
---------------	--------------------------	---	--------

ref.

description

pack  
q.tyEAN13  
8011017**CLAMPING****QUICK ADJUSTING BAND CLAMP**

For gluing picture frames, furniture, shelves

**957.00** 4 m length

1

957005

**RATCHET CLAMP****957.50** max opening **50** mm

5

957500

**MINI SPRING CLAMPS****958.00** kit **4** mini spring clamps - max opening **18** mm

10

958002

**SPRING CLAMPS****958.05** max opening **30** mm

10

958057

**958.07** max opening **40** mm

10

958071

**958.10** max opening **60** mm

10

958101

**958.14** max opening **70** mm

10

958149

 PG pack

 neutral pack



**ROTARY DRILL CLAMP**

**960.00** with collar  $\varnothing$  43 mm

1

960005



**MILL ATTACHMENT**

**970.00** with collar  $\varnothing$  43 mm

1

970004



**MOBILE DRILL STAND**

**972.00** for drilling and hole-sawing, horizontally, vertically  
0-45° - with collar  $\varnothing$  43 mm

1

972008



**UNIVERSAL ANGLE GRINDER STAND**

For cutting metal. Working surface with quick action clamping device

**50.080** - disc  $\varnothing$  150/230 mm  
- vice jaw opening 100 mm  
- sheet metal base 290 x 295 mm

1

500805

**50.090** - disc  $\varnothing$  115/125 mm  
- vice jaw opening 77 mm  
- cast iron base 240 x 190 mm

1

500904



**UNIVERSAL DRILL STAND**

For precision and safety drilling. Working surface with clamping grooves for fastening clamping blocks or vices

<b>50.020</b>	with rotary collar $\varnothing$ <b>43</b> mm - height <b>420</b> mm - stroke <b>60</b> mm - depth <b>96</b> mm - working height <b>240</b> mm - column $\varnothing$ <b>22</b> mm - with return spring - <b>aluminium</b> base <b>220 x 175</b> mm	1	500201
<b>50.030</b>	with rotary collar $\varnothing$ <b>60</b> mm - with <b>3</b> reducing collars $\varnothing$ <b>43-50-53</b> mm - height <b>500</b> mm - stroke <b>65</b> mm - depth <b>95</b> mm - working height <b>320</b> mm - column $\varnothing$ <b>30</b> mm - with return spring - <b>aluminium</b> base <b>250 x 180</b> mm - professional model	1	500300
<b>50.040</b>	with rotary collar $\varnothing$ <b>60</b> mm - with <b>3</b> reducing collars $\varnothing$ <b>43-50-53</b> mm - height <b>500</b> mm - stroke <b>65</b> mm - depth <b>95</b> mm - working height <b>320</b> mm - column $\varnothing$ <b>30</b> mm - with return spring - <b>cast iron</b> base <b>250 x 180</b> mm - professional model	1	500409

**REDUCING COLLAR** for drill stands

<b>43.034</b>	$\varnothing$ <b>43 x 34</b> mm	1	430348
<b>43.037</b>	$\varnothing$ <b>43 x 37</b> mm	1	430379
<b>43.038</b>	$\varnothing$ <b>43 x 38</b> mm	1	430386
<b>43.384</b>	$\varnothing$ <b>43 x 38,4</b> mm	1	433844
<b>60.043</b>	$\varnothing$ <b>60 x 43</b> mm	1	600437
<b>60.046</b>	$\varnothing$ <b>60 x 46</b> mm	1	600468
<b>60.050</b>	$\varnothing$ <b>60 x 50</b> mm	1	600505
<b>60.053</b>	$\varnothing$ <b>60 x 53</b> mm	1	600536
<b>60.054</b>	$\varnothing$ <b>60 x 54</b> mm	1	600543
<b>60.056</b>	$\varnothing$ <b>60 x 56</b> mm	1	600567



**TILE AND GLASS DRILL**



<b>728.00</b>	∅ 3 mm	5	728001
<b>728.10</b>	∅ 4 mm	5	728100
<b>728.20</b>	∅ 5 mm	5	728209
<b>728.30</b>	∅ 6 mm	5	728308
<b>728.40</b>	∅ 8 mm	5	728407
<b>728.50</b>	∅ 10 mm	5	728506
<b>728.60</b>	∅ 12 mm	5	728605



**DUST CATCHER**

<b>565.00</b>	for drill bits from ∅ 4 mm to ∅ 10 mm	10	565002
---------------	---------------------------------------	----	--------

**DRILLS ASSORTMENT**



<b>15.606</b>	<b>5 WOOD</b> drill bits ∅ 4 - 5 - 6 - 8 - 10 mm	2	156064
<b>15.607</b>	<b>8 WOOD</b> drill bits ∅ 3 - 4 - 5 - 6 - 7 - 8 - 9 - 10 mm	2	156071
<b>15.608</b>	<b>5 MASONRY</b> drill bits ∅ 4 - 5 - 6 - 8 - 10 mm	2	156088
<b>15.610</b>	<b>8 MASONRY</b> drill bits ∅ 3 - 4 - 5 - 6 - 7 - 8 - 9 - 10 mm	2	156101
<b>15.615</b>	<b>13 HSS</b> drill bits ∅ 1,5 - 2 - 2,5 - 3 - 3,3 - 3,5 - 4 - 4,2 - 4,5 - 5 - 5,5 - 6 - 6,5 mm	2	156156
<b>15.620</b>	<b>13 HSS</b> drill bits ∅ 2 - 2,5 - 3 - 3,5 - 4 - 4,5 - 5 - 5,5 - 6 - 6,5 - 7 - 7,5 - 8 mm	2	156200
<b>15.630</b>	<b>9 MASONRY - HSS</b> drill bits <b>HSS</b> ∅ 3 - 4 - 5 - 6 - 8 mm <b>MASONRY</b> ∅ 4 - 5 - 6 - 8 mm	2	156309
<b>15.640</b>	<b>9 WOOD - MASONRY - HSS</b> drill bits ∅ 5 - 6 - 8 mm	2	156408



**HSS - DIN 338 HIGH SPEED STEEL TWIST DRILL**

Hexagonal shank 1/4"

<b>465.02</b>	∅ 2 mm	10	465029
<b>465.03</b>	∅ 3 mm	10	465036
<b>465.04</b>	∅ 4 mm	10	465043
<b>465.05</b>	∅ 5 mm	10	465050

**HSS - DIN 338 HIGH SPEED STEEL TWIST DRILL**

∅ mm	PG BLISTER		BULK		q.ty
	ref.	EAN13 8011017	ref.	EAN13 8011017	
<b>1</b>	<b>10.010 - 2 drills</b>	100104	<b>17.010</b>	170107	<b>10</b>
<b>1,5</b>	<b>10.015 - 2 drills</b>	100159	<b>17.015</b>	170152	<b>10</b>
<b>2</b>	<b>10.020 - 2 drills</b>	100203	<b>17.020</b>	170206	<b>10</b>
<b>2,5</b>	<b>10.025 - 2 drills</b>	100258	<b>17.025</b>	170251	<b>10</b>
<b>3</b>	<b>10.030 - 2 drills</b>	100302	<b>17.030</b>	170305	<b>10</b>
<b>3,5</b>	<b>10.035 - 2 drills</b>	100357	<b>17.035</b>	170350	<b>10</b>
<b>4</b>	<b>10.040 - 2 drills</b>	100401	<b>17.040</b>	170404	<b>10</b>
<b>4,5</b>	<b>10.045</b>	100456	<b>17.045</b>	170459	<b>10</b>
<b>5</b>	<b>10.050</b>	100500	<b>17.050</b>	170503	<b>10</b>
<b>5,5</b>	<b>10.055</b>	100555	<b>17.055</b>	170558	<b>10</b>
<b>6</b>	<b>10.060</b>	100609	<b>17.060</b>	170602	<b>10</b>
<b>6,5</b>	<b>10.065</b>	100654	<b>17.065</b>	170657	<b>10</b>
<b>7</b>	<b>10.070</b>	100708	<b>17.070</b>	170701	<b>10</b>
<b>7,5</b>	<b>10.075</b>	100753	<b>17.075</b>	170756	<b>10</b>
<b>8</b>	<b>10.080</b>	100807	<b>17.080</b>	170800	<b>10</b>
<b>8,5</b>	<b>10.085</b>	100852	<b>17.085</b>	170855	<b>10</b>
<b>9</b>	<b>10.090</b>	100906	<b>17.090</b>	170909	<b>10</b>
<b>9,5</b>	<b>10.095</b>	100951	<b>17.095</b>	170954	<b>10</b>
<b>10</b>	<b>10.100</b>	101002	<b>17.100</b>	171005	<b>10</b>
<b>10,5</b>	<b>10.105</b>	101057	<b>17.105</b>	171050	<b>10</b>
<b>11</b>	<b>10.110</b>	101101	<b>17.110</b>	171104	<b>10</b>
<b>11,5</b>	<b>10.115</b>	101156	<b>17.115</b>	171159	<b>10</b>
<b>12</b>	<b>10.120</b>	101200	<b>17.120</b>	171203	<b>10</b>
<b>12,5</b>	<b>10.125</b>	101255	<b>17.125</b>	171258	<b>10</b>
<b>13</b>	<b>10.130</b>	101309	<b>17.130</b>	171302	<b>10</b>
<b>13,5</b>			<b>17.135</b>	171357	<b>5</b>
<b>14</b>			<b>17.140</b>	171401	<b>5</b>
<b>14,5</b>			<b>17.145</b>	171456	<b>5</b>
<b>15</b>			<b>17.150</b>	171500	<b>5</b>
<b>15,5</b>			<b>17.155</b>	171555	<b>5</b>
<b>16</b>			<b>17.160</b>	171609	<b>5</b>

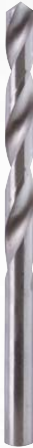

**MASONRY CARBIDE TIPPED PLATE DRILL - DIN 8039** - for marble, granite, cement, rock, concrete, bricks and tiles - rotopercussion use



ø mm	PG BLISTER		BULK		q.ty
	ref.	EAN13 8011017	ref.	EAN13 8011017	
<b>3</b>	<b>15.030</b>	150307	<b>16.030</b>	160306	<b>10</b>
<b>4</b>	<b>15.040</b>	150406	<b>16.040</b>	160405	<b>10</b>
<b>5</b>	<b>15.050</b>	150505	<b>16.050</b>	160504	<b>10</b>
<b>5,5</b>			<b>16.055</b>	160559	<b>10</b>
<b>6</b>	<b>15.060</b>	150604	<b>16.060</b>	160603	<b>10</b>
<b>6,5</b>			<b>16.065</b>	160658	<b>10</b>
<b>7</b>	<b>15.070</b>	150703	<b>16.070</b>	160702	<b>10</b>
<b>8</b>	<b>15.080</b>	150802	<b>16.080</b>	160801	<b>10</b>
<b>9</b>	<b>15.090</b>	150901	<b>16.090</b>	160900	<b>10</b>
<b>10</b>	<b>15.100</b>	151007	<b>16.100</b>	161006	<b>10</b>
<b>11</b>			<b>16.110</b>	161105	<b>10</b>
<b>12</b>	<b>15.120</b>	151205	<b>16.120</b>	161204	<b>10</b>
<b>13</b>			<b>16.130</b>	161303	<b>10</b>
<b>14</b>	<b>15.140</b>	151403	<b>16.140</b>	161402	<b>10</b>
<b>15</b>			<b>16.150</b>	161501	<b>10</b>
<b>16</b>			<b>16.160</b>	161600	<b>10</b>
<b>18</b>			<b>16.180</b>	161808	<b>10</b>
<b>20</b>			<b>16.200</b>	162003	<b>10</b>

**MASONRY CARBIDE TIPPED PLATE DRILL - DIN 8039 - 400 mm length**

ø mm	ref.	EAN13 8011017	q.ty
<b>8</b>	<b>16.408</b>	164083	<b>1</b>
<b>10</b>	<b>16.410</b>	164106	<b>1</b>
<b>12</b>	<b>16.412</b>	164120	<b>1</b>
<b>14</b>	<b>16.414</b>	164144	<b>1</b>
<b>16</b>	<b>16.416</b>	164168	<b>1</b>
<b>18</b>	<b>16.418</b>	164182	<b>1</b>
<b>20</b>	<b>16.420</b>	164205	<b>1</b>
<b>22</b>	<b>16.422</b>	164229	<b>1</b>
<b>25</b>	<b>16.425</b>	164250	<b>1</b>



**MASONRY CARBIDE TIPPED PLATE DRILL - DIN 8039 - 600 mm length**

ø mm	ref.	EAN13 8011017	q.ty
<b>10</b>	<b>16.610</b>	166100	<b>1</b>
<b>12</b>	<b>16.612</b>	166124	<b>1</b>
<b>14</b>	<b>16.614</b>	166148	<b>1</b>
<b>16</b>	<b>16.616</b>	166162	<b>1</b>
<b>18</b>	<b>16.618</b>	166186	<b>1</b>
<b>20</b>	<b>16.620</b>	166209	<b>1</b>

**CV WOOD DRILL - DIN 7487**

ø mm	PG BLISTER		BULK		q.ty
	ref.	EAN13 8011017	ref.	EAN13 8011017	
3	<b>630.03</b>	630038	<b>14.003</b>	140032	<b>10</b>
4	<b>630.04</b>	630045	<b>14.004</b>	140049	<b>10</b>
5	<b>630.05</b>	630052	<b>14.005</b>	140056	<b>10</b>
6	<b>630.06</b>	630069	<b>14.006</b>	140063	<b>10</b>
7	<b>630.07</b>	630076	<b>14.007</b>	140070	<b>10</b>
8	<b>630.08</b>	630083	<b>14.008</b>	140087	<b>10</b>
9	<b>630.09</b>	630090	<b>14.009</b>	140094	<b>10</b>
10	<b>630.10</b>	630106	<b>14.010</b>	140100	<b>10</b>
11	<b>630.11</b>	630113	<b>14.011</b>	140117	<b>10</b>
12	<b>630.12</b>	630120	<b>14.012</b>	140124	<b>10</b>
13	<b>630.13</b>	630137	<b>14.013</b>	140131	<b>10</b>
14	<b>630.14</b>	630144	<b>14.014</b>	140148	<b>10</b>
15			<b>14.015</b>	140155	<b>10</b>
16			<b>14.016</b>	140162	<b>10</b>
18			<b>14.018</b>	140186	<b>5</b>
20			<b>14.020</b>	140209	<b>5</b>
22			<b>14.022</b>	140223	<b>5</b>
24			<b>14.024</b>	140247	<b>5</b>
26			<b>14.026</b>	140261	<b>2</b>
28			<b>14.028</b>	140285	<b>2</b>
30			<b>14.030</b>	140308	<b>2</b>

**CV WOOD DRILL - 250 mm length**

ø mm	ref.	EAN13 8011017	q.ty
6	<b>14.206</b>	142067	<b>10</b>
7	<b>14.207</b>	142074	<b>10</b>
8	<b>14.208</b>	142081	<b>10</b>
9	<b>14.209</b>	142098	<b>10</b>
10	<b>14.210</b>	142104	<b>10</b>
11	<b>14.211</b>	142111	<b>10</b>
12	<b>14.212</b>	142128	<b>10</b>
13	<b>14.213</b>	142135	<b>5</b>
14	<b>14.214</b>	142142	<b>5</b>
15	<b>14.215</b>	142159	<b>5</b>
16	<b>14.216</b>	142166	<b>5</b>
18	<b>14.218</b>	142180	<b>2</b>
20	<b>14.220</b>	142203	<b>2</b>
22	<b>14.222</b>	142227	<b>2</b>
24	<b>14.224</b>	142241	<b>2</b>



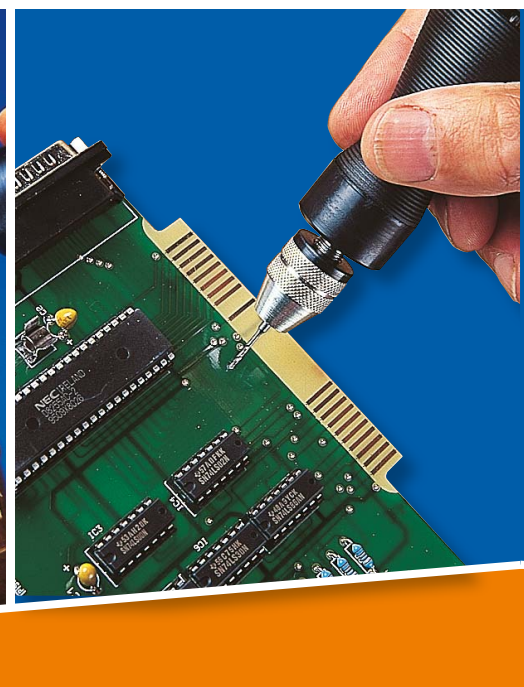



mini

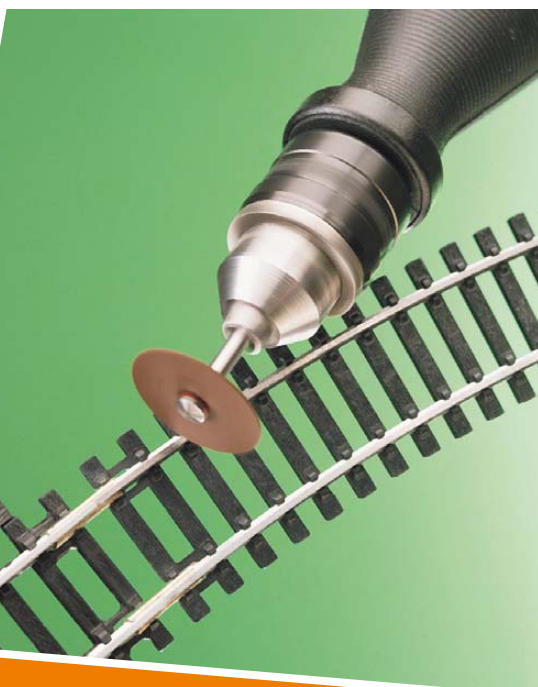
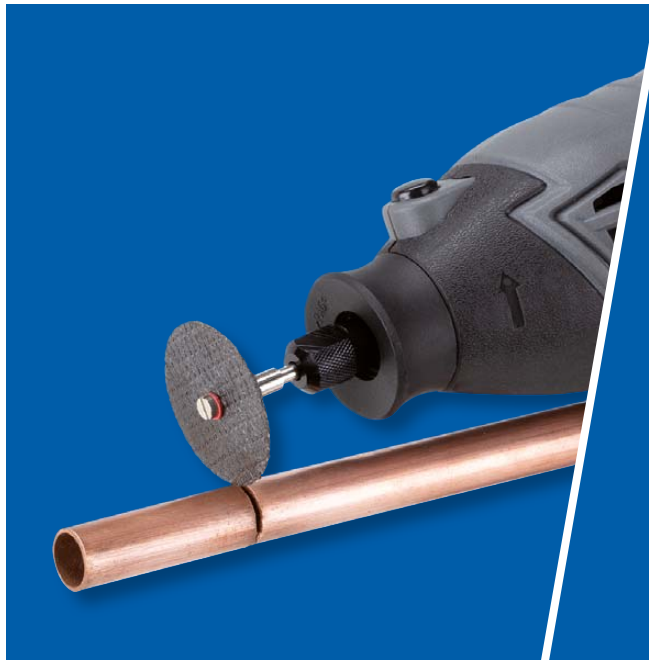

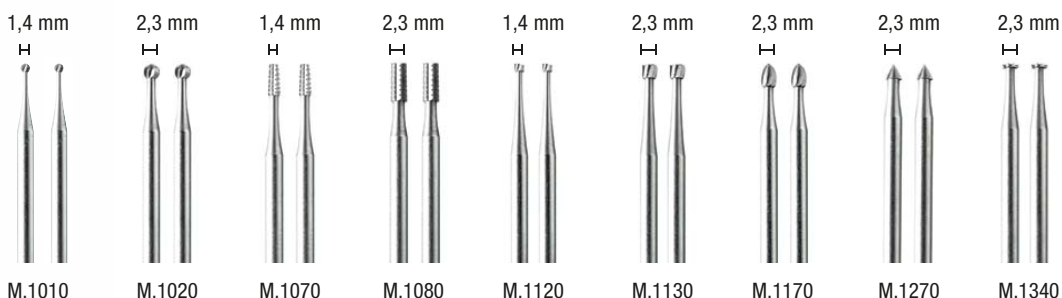

**STEEL ENGRAVING CUTTERS**

For carving, engraving and routing on wood, fiberglass, soft metal, plaster and plastic

<b>M.1010</b>	2 engraving cutters ø <b>1,4</b> mm ball - shank ø <b>2,35</b> mm	5	090009
<b>M.1020</b>	2 engraving cutters ø <b>2,3</b> mm ball - shank ø <b>2,35</b> mm	5	090016
<b>M.1070</b>	2 engraving cutters ø <b>1,4</b> mm cylindrical - shank ø <b>2,35</b> mm	5	090023
<b>M.1080</b>	2 engraving cutters ø <b>2,3</b> mm cylindrical - shank ø <b>2,35</b> mm	5	090030
<b>M.1120</b>	2 engraving cutters ø <b>1,4</b> mm reverse taper - shank ø <b>2,35</b> mm	5	090047
<b>M.1130</b>	2 engraving cutters ø <b>2,3</b> mm reverse taper - shank ø <b>2,35</b> mm	5	090054
<b>M.1170</b>	2 engraving cutters ø <b>2,3</b> mm flame - shank ø <b>2,35</b> mm	5	090061
<b>M.1270</b>	2 engraving cutters ø <b>2,3</b> mm countersink - shank ø <b>2,35</b> mm	5	090078
<b>M.1340</b>	2 engraving cutters ø <b>2,3</b> mm wheel - shank ø <b>2,35</b> mm	5	090085

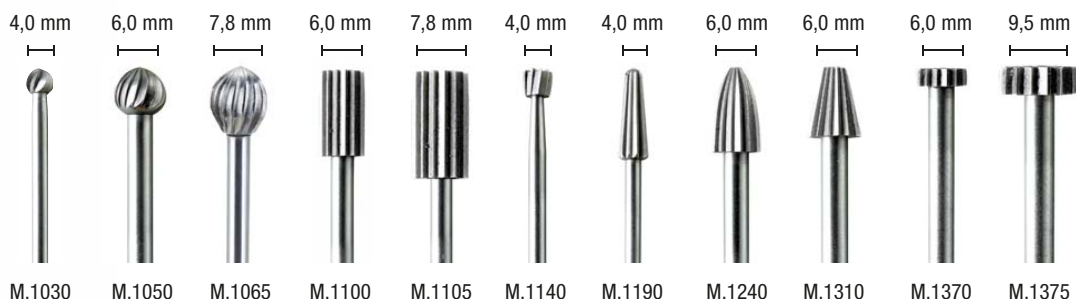

**STEEL CUTTERS**

For carving, engraving, milling, slotting and countersinking on wood, fiberglass, soft metal, plaster and plastic

<b>M.1030</b>	ø <b>4,0</b> mm ball - shank ø <b>2,35</b> mm	5	090092
<b>M.1050</b>	ø <b>6,0</b> mm ball - shank ø <b>3,0</b> mm	5	090108
<b>M.1065</b>	ø <b>7,8</b> mm oval - shank ø <b>3,20</b> mm	5	092928
<b>M.1100</b>	ø <b>6,0</b> mm cylindrical - shank ø <b>3,0</b> mm	5	090115
<b>M.1105</b>	ø <b>7,8</b> mm cylindrical - shank ø <b>3,20</b> mm	5	092935
<b>M.1140</b>	ø <b>4,0</b> mm reverse taper - shank ø <b>2,35</b> mm	5	090122
<b>M.1190</b>	ø <b>4,0</b> mm flame - shank ø <b>2,35</b> mm	5	090139
<b>M.1240</b>	ø <b>6,0</b> mm cone - shank ø <b>3,0</b> mm	5	090146
<b>M.1310</b>	ø <b>6,0</b> mm point - shank ø <b>3,0</b> mm	5	090153
<b>M.1370</b>	ø <b>6,0</b> mm wheel - shank ø <b>3,0</b> mm	5	090160
<b>M.1375</b>	ø <b>9,5</b> mm wheel - shank ø <b>3,20</b> mm	5	092942

ref.

description

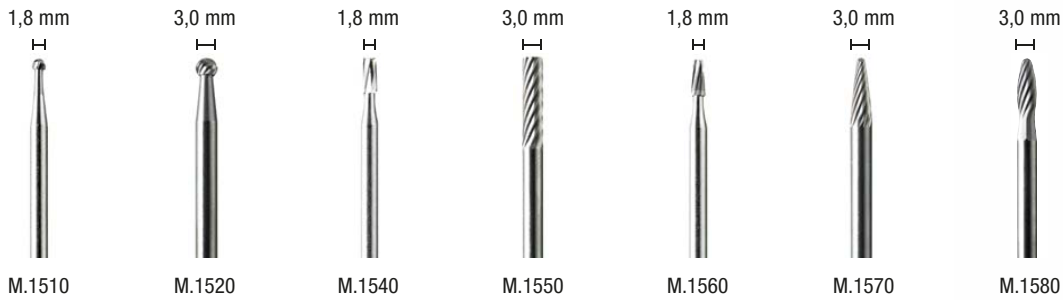
pack  
q.tyEAN13  
8011017**CARVING  
ENGRAVING  
MILLING****TUNGSTEN CARBIDE CUTTERS**

For material removal, smoothing and shaping. Particularly indicated for hardened and stainless steel, cast iron, non-ferrous metal, fired ceramic, wood, plastic and other hard materials

<b>M.1510</b>	∅ 1,8 mm ball - shank ∅ 2,35 mm	5	090177
<b>M.1520</b>	∅ 3,0 mm ball - shank ∅ 3,0 mm	5	090184
<b>M.1540</b>	∅ 1,8 mm cylindrical - shank ∅ 2,35 mm	5	090191
<b>M.1550</b>	∅ 3,0 mm cylindrical - shank ∅ 3,0 mm	5	090207
<b>M.1560</b>	∅ 1,8 mm cone - shank ∅ 2,35 mm	5	090214
<b>M.1570</b>	∅ 3,0 mm cone - shank ∅ 3,0 mm	5	090221
<b>M.1580</b>	∅ 3,0 mm flame - shank ∅ 3,0 mm	5	090238

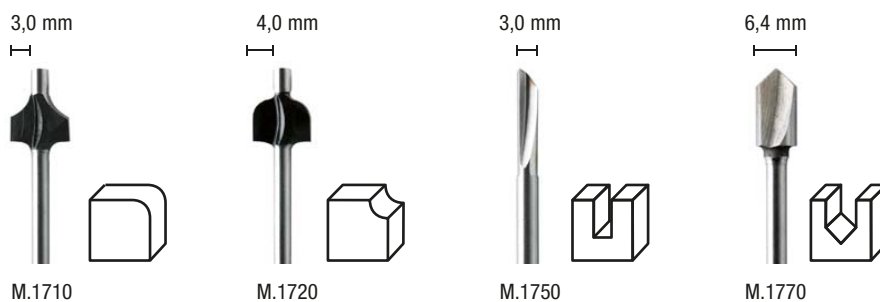
**HSS ROUTER BITS**

For finishing wooden edges and for different kinds of grooves and profiles

<b>M.1710</b>	r = 3,0 mm convex profiles - shank ∅ 3,0 mm	2	090320
<b>M.1720</b>	r = 4,0 mm concave profiles - shank ∅ 3,0 mm	2	090337
<b>M.1750</b>	∅ 3,0 mm straight grooves - shank ∅ 3,0 mm	2	090344
<b>M.1770</b>	∅ 6,4 mm V grooves - shank ∅ 3,0 mm	2	090351



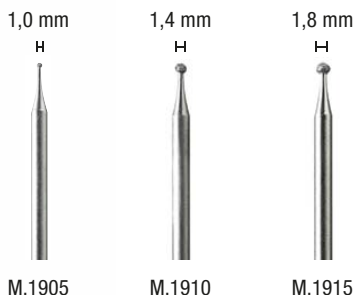

**DIAMOND POINTS**

Coated with diamond particles, especially indicated for fine detail works like engraving, carving, or finishing materials like glass, ceramic, semi-precious stones, metal, wood and other hard materials

<b>M.1905</b>	∅ 1,0 mm ball - shank ∅ 2,35 mm	5	090245
<b>M.1910</b>	∅ 1,4 mm ball - shank ∅ 2,35 mm	5	090252
<b>M.1915</b>	∅ 1,8 mm ball - shank ∅ 2,35 mm	5	090269

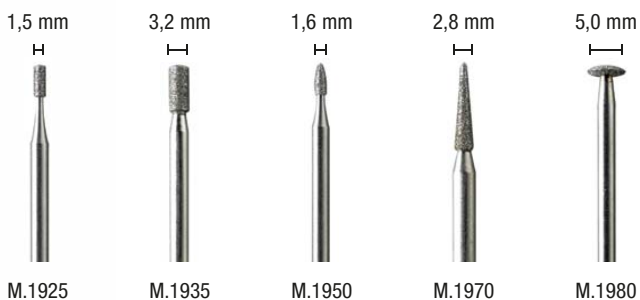

**DIAMOND POINTS**

Coated with diamond particles, especially indicated for fine detail works like engraving, carving, or finishing materials like glass, ceramic, semi-precious stones, metal, wood and other hard materials

<b>M.1925</b>	∅ 1,5 mm cylindrical - shank ∅ 2,35 mm	5	090276
<b>M.1935</b>	∅ 3,2 mm cylindrical - shank ∅ 2,35 mm	5	090283
<b>M.1950</b>	∅ 1,6 mm flame - shank ∅ 2,35 mm	5	090290
<b>M.1970</b>	∅ 2,8 mm point - shank ∅ 2,35 mm	5	090306
<b>M.1980</b>	∅ 5,0 mm disc - shank ∅ 2,35 mm	5	090313



**RUBY GRINDING STONES**

High abrasive power. For sharpening, deburring and general grinding of most materials. Particularly indicated for precision grinding

<b>M.2010</b>	2 grinding stones $\varnothing$ 3 x 8 mm - cylindrical - shank $\varnothing$ 3,0 mm	5	090368
<b>M.2025</b>	2 grinding stones $\varnothing$ 5 x 10 mm - cylindrical - shank $\varnothing$ 3,0 mm	5	090375
<b>M.2040</b>	2 grinding stones $\varnothing$ 8 x 10 mm - cylindrical - shank $\varnothing$ 3,0 mm	5	090382
<b>M.2055</b>	2 grinding stones $\varnothing$ 10 x 12 mm - cylindrical - shank $\varnothing$ 3,0 mm	5	090399
<b>M.2070</b>	2 grinding stones $\varnothing$ 12 x 15 mm - cylindrical - shank $\varnothing$ 3,0 mm	5	090405
<b>M.2085</b>	2 grinding stones $\varnothing$ 3 x 8 mm - cone - shank $\varnothing$ 2,35 mm	5	090412
<b>M.2100</b>	2 grinding stones $\varnothing$ 5 x 10 mm - cone - shank $\varnothing$ 2,35 mm	5	090429
<b>M.2115</b>	2 grinding stones $\varnothing$ 8 x 12 mm - cone - shank $\varnothing$ 3,0 mm	5	090436

**RUBY GRINDING STONES**

High abrasive power. For sharpening, deburring and general grinding of most materials. Particularly indicated for precision grinding

<b>M.2130</b>	2 grinding stones $\varnothing$ 6 x 10 mm - bullet - shank $\varnothing$ 3,0 mm	5	090443
<b>M.2145</b>	2 grinding stones $\varnothing$ 10 x 20 mm - bullet - shank $\varnothing$ 3,0 mm	5	090450
<b>M.2160</b>	2 grinding stones $\varnothing$ 6 mm - ball - shank $\varnothing$ 3,0 mm	5	090467
<b>M.2175</b>	2 grinding stones $\varnothing$ 10 mm - ball - shank $\varnothing$ 3,0 mm	5	090474
<b>M.2190</b>	2 grinding stones $\varnothing$ 6 x 12 mm - cylin./cone - shank $\varnothing$ 3,0 mm	5	090481
<b>M.2205</b>	2 grinding stones $\varnothing$ 8 x 15 mm - cylin./cone - shank $\varnothing$ 3,0 mm	5	090498
<b>M.2220</b>	2 grinding stones $\varnothing$ 10 x 20 mm - cylin./cone - shank $\varnothing$ 3,0 mm	5	090504
<b>M.2235</b>	2 grinding stones $\varnothing$ 8 x 6 mm - reverse taper - shank $\varnothing$ 3,0 mm	5	090511





**SILICON CARBIDE GRINDING STONES**

Very high abrasive power. For sharpening hard metal tools and for finishing and precision works. For engraving and working stone, glass, crystals, ceramic and porcelain

<b>M.2410</b>	2 grinding stones $\varnothing$ 3 x 8 mm - cone - shank $\varnothing$ 2,35 mm	5	090528
<b>M.2420</b>	2 grinding stones $\varnothing$ 5 x 10 mm - cone - shank $\varnothing$ 2,35 mm	5	090535
<b>M.2435</b>	2 grinding stones $\varnothing$ 4 mm - ball - shank $\varnothing$ 3,0 mm	5	090542
<b>M.2450</b>	2 grinding stones $\varnothing$ 8 x 6 mm - reverse taper - shank $\varnothing$ 3,0 mm	5	090559
<b>M.2465</b>	2 grinding stones $\varnothing$ 6 x 10 mm - round head - shank $\varnothing$ 3,0 mm	5	090566
<b>M.2480</b>	2 grinding stones $\varnothing$ 5 x 10 mm - flame - shank $\varnothing$ 3,0 mm	5	090573

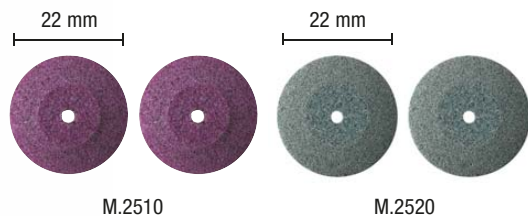

**LENTICULAR GRINDING STONES**

<b>M.2510</b>	2 grinding stones $\varnothing$ 22 mm - ruby abrasive	5	090580
<b>M.2520</b>	2 grinding stones $\varnothing$ 22 mm - silicon carbide	5	090597

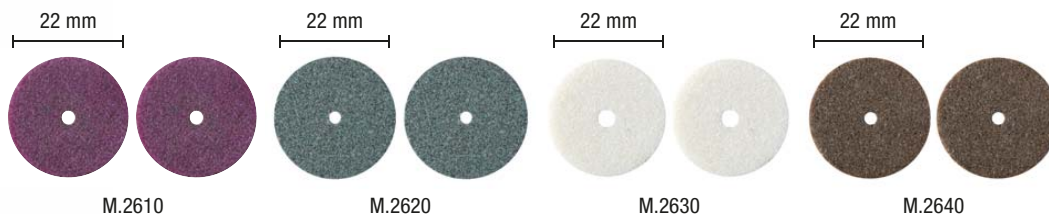

**WHEEL GRINDING STONES**

<b>M.2610</b>	2 grinding stones $\varnothing$ 22 mm - ruby abrasive	5	090603
<b>M.2620</b>	2 grinding stones $\varnothing$ 22 mm - silicon carbide	5	090610
<b>M.2630</b>	2 grinding stones $\varnothing$ 22 mm - white abrasive	5	090627
<b>M.2640</b>	2 grinding stones $\varnothing$ 22 mm - brown abrasive	5	090634

ref.

description

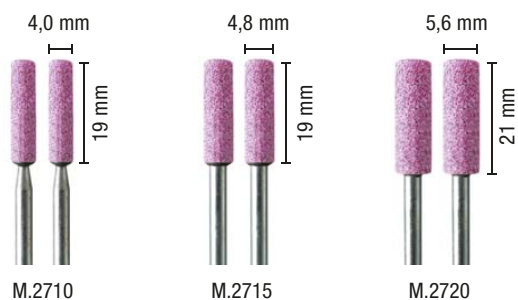
pack  
q.tyEAN13  
8011017**GRINDING  
SHARPENING****CHAIN SAW RUBY SHARPENING STONES**

High abrasive power. For sharpening of chain saw blades

<b>M.2710</b>	2 grinding stones <b>4,0 x 19</b> mm - cylindrical - shank $\varnothing$ <b>3,0</b> mm	5	090641
<b>M.2715</b>	2 grinding stones <b>4,8 x 19</b> mm - cylindrical - shank $\varnothing$ <b>3,0</b> mm	5	090658
<b>M.2720</b>	2 grinding stones <b>5,6 x 21</b> mm - cylindrical - shank $\varnothing$ <b>3,0</b> mm	5	090665

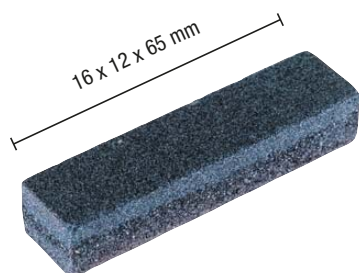
**STONE DRESSER**

For restoring, cleaning and reshaping of grinding stones

<b>M.2910</b>	<b>16 x 12 x 65</b> mm - double grain	5	090672
---------------	---------------------------------------	---	--------





**FLAP GRINDING WHEELS**

For grinding and polishing of metal, rubber and plastic flat and contoured surfaces and for rust removal

<b>M.3020</b>	ø 20 x 5 mm - grain 80 - shank ø 3,0 mm	5	090689
<b>M.3030</b>	ø 30 x 10 mm - grain 80 - shank ø 3,0 mm	5	090696

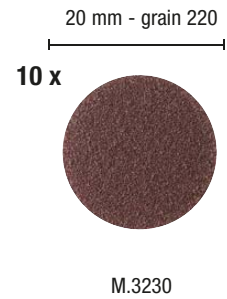
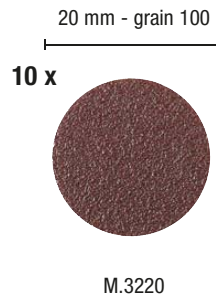
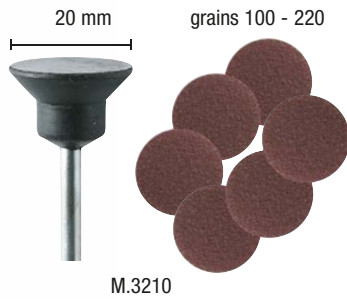

**RUBBER BACKING PAD AND ADHESIVE SANDING DISCS**

For sanding, grinding, shaping wood, plastic, rubber and removing rust from metal surfaces

<b>M.3210</b>	rubber backing pad ø 20 mm - shank ø 3,2 mm - 6 abrasive discs - assorted grades	5	090702
<b>M.3220</b>	10 abrasive discs ø 20 mm - grain 100	5	090719
<b>M.3230</b>	10 abrasive discs ø 20 mm - grain 220	5	090726

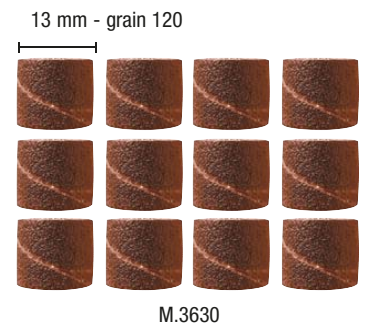
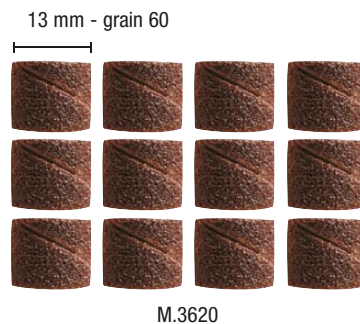
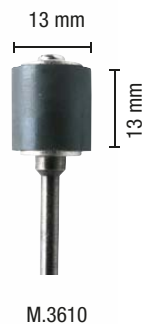

**SANDING DRUM MANDREL AND SANDING BELTS**

For sanding, grinding, shaping wood, plastic, rubber and removing rust from metal surfaces

<b>M.3610</b>	sanding drum mandrel ø 13 x 13 mm - shank ø 3,2 mm	5	090733
<b>M.3620</b>	12 sanding belts ø 13 mm - grain 60	5	090740
<b>M.3630</b>	12 sanding belts ø 13 mm - grain 120	5	090757

ref.

description

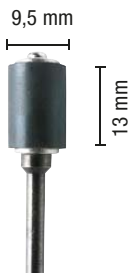
pack  
q.tyEAN13  
8011017**SANDING**

M.3640

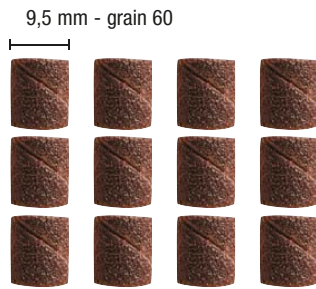

M.3650

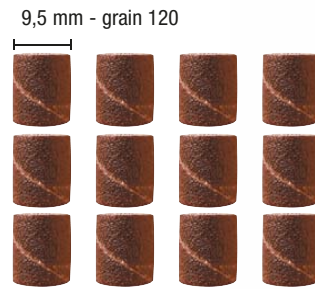

M.3660

**SANDING DRUM MANDREL AND SANDING BELTS**

For sanding, grinding, shaping wood, plastic, rubber and removing rust from metal surfaces

<b>M.3640</b>	sanding drum mandrel $\varnothing$ <b>9,5 x 13</b> mm - shank $\varnothing$ <b>3,2</b> mm	5	092959
<b>M.3650</b>	<b>12</b> sanding belts $\varnothing$ <b>9,5</b> mm - grain <b>60</b>	5	092966
<b>M.3660</b>	<b>12</b> sanding belts $\varnothing$ <b>9,5</b> mm - grain <b>120</b>	5	092973

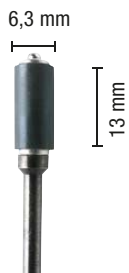

M.3670

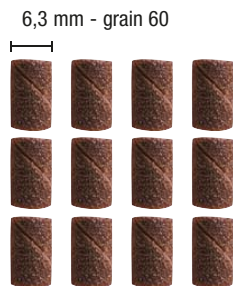

M.3680

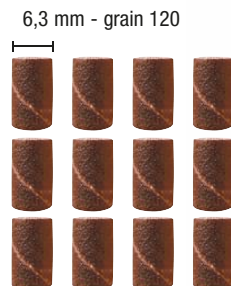

M.3690

**SANDING DRUM MANDREL AND SANDING BELTS**

For sanding, grinding, shaping wood, plastic, rubber and removing rust from metal surfaces

<b>M.3670</b>	sanding drum mandrel $\varnothing$ <b>6,3 x 13</b> mm - shank $\varnothing$ <b>3,2</b> mm	5	092980
<b>M.3680</b>	<b>12</b> sanding belts $\varnothing$ <b>6,3</b> mm - grain <b>60</b>	5	092997
<b>M.3690</b>	<b>12</b> sanding belts $\varnothing$ <b>6,3</b> mm - grain <b>120</b>	5	093000

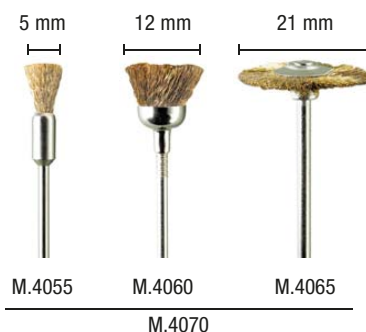

**STEEL BRUSHES:** for cleaning and deburring metal, wood and plastic, for removing rust and corrosion and cleaning welding connections

**BRASS BRUSHES:** for cleaning, deburring and polishing wood, soft metals like gold, copper and brass without scratching and for cleaning electric components

<b>M.4005</b>	Ø 5 mm - steel end brush - shank Ø 2,35 mm	5	090764
<b>M.4010</b>	Ø 12 mm - steel cup brush - shank Ø 2,35 mm	5	090771
<b>M.4015</b>	Ø 21 mm - steel wheel brush - shank Ø 2,35 mm	5	090788
<b>M.4020</b>	3 assorted steel brushes	5	090795
<b>M.4055</b>	Ø 5 mm - brass end brush - shank Ø 2,35 mm	5	090801
<b>M.4060</b>	Ø 12 mm - brass cup brush - shank Ø 2,35 mm	5	090818
<b>M.4065</b>	Ø 21 mm - brass wheel brush - shank Ø 2,35 mm	5	090825
<b>M.4070</b>	3 assorted brass brushes	5	090832



**BLACK BRISTLE BRUSHES:** for light deburring, cleaning and polishing. Particularly indicated for silverware, jewelry and other precious materials

**WHITE NYLON BRUSHES:** for cleaning and polishing precious metals and other delicate surfaces

<b>M.4105</b>	Ø 5 mm - black bristle end brush - shank Ø 2,35 mm	5	090849
<b>M.4110</b>	Ø 12 mm - black bristle cup brush - shank Ø 2,35 mm	5	090856
<b>M.4115</b>	Ø 21 mm - black bristle wheel brush - shank Ø 2,35 mm	5	090863
<b>M.4120</b>	3 assorted black bristle brushes	5	090870
<b>M.4155</b>	Ø 5 mm - white nylon end brush - shank Ø 2,35 mm	5	090887
<b>M.4160</b>	Ø 12 mm - white nylon cup brush - shank Ø 2,35 mm	5	090894
<b>M.4165</b>	Ø 21 mm - white nylon wheel brush - shank Ø 2,35 mm	5	090900
<b>M.4170</b>	3 assorted white nylon brushes	5	090917

ref.

description

pack  
q.tyEAN13  
8011017**CLEANING  
POLISHING****SILICON POLISHERS**

For polishing porcelain, ceramic, precious metals and enamels

<b>M.4305</b>	∅ 12 mm - disc - shank ∅ 2,35 mm	5	090924
<b>M.4310</b>	∅ 12 mm - lenticular - shank ∅ 2,35 mm	5	090931

**RUBBER POLISHING POINTS**

For finishing and polishing all ferrous metals, removing of scratches and imperfections and cleaning of carving on ceramic, ferrous materials and most stones

<b>M.4505</b>	∅ 6,0 mm - flame - shank ∅ 3,0 mm	5	090948
<b>M.4510</b>	∅ 5,0 mm - bullet - shank ∅ 3,0 mm	5	090955
<b>M.4515</b>	∅ 6,0 mm - cylindrical - shank ∅ 3,0 mm	5	090962

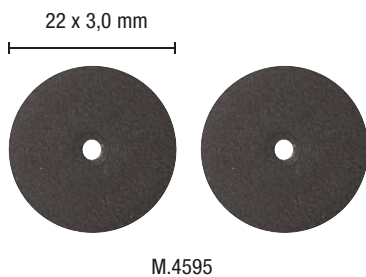
**BROWN RUBBER POLISHING DISC**

For polishing and removing scratches on ferrous materials, stones and ceramics

<b>M.4595</b>	2 discs ∅ 22 x 3,0 mm	5	090979
---------------	-----------------------	---	--------



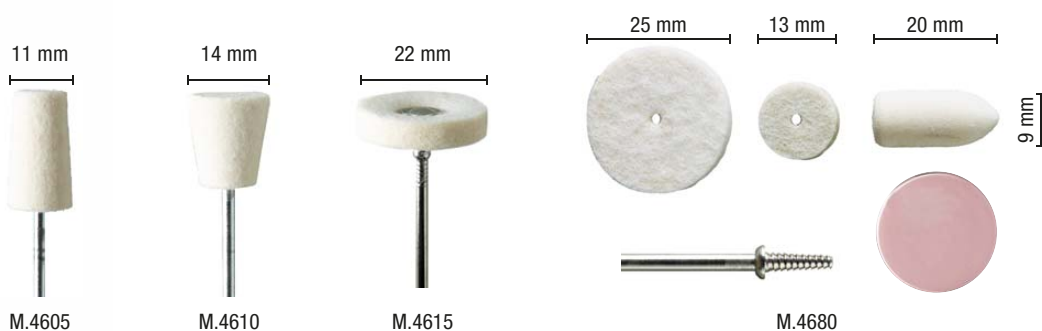

**FELT DISCS**

For polishing metal, glass, ceramics, marbles, precious metals, stones and plastic

<b>M.4605</b>	ø 11 mm - taper - shank ø 2,35 mm	5	090986
<b>M.4610</b>	ø 14 mm - reverse taper - shank ø 2,35 mm	5	090993
<b>M.4615</b>	ø 22 mm - wheel - shank ø 2,35 mm	5	091006
<b>M.4680</b>	kit 3 assorted felt points + mandrel + polishing paste	5	091013

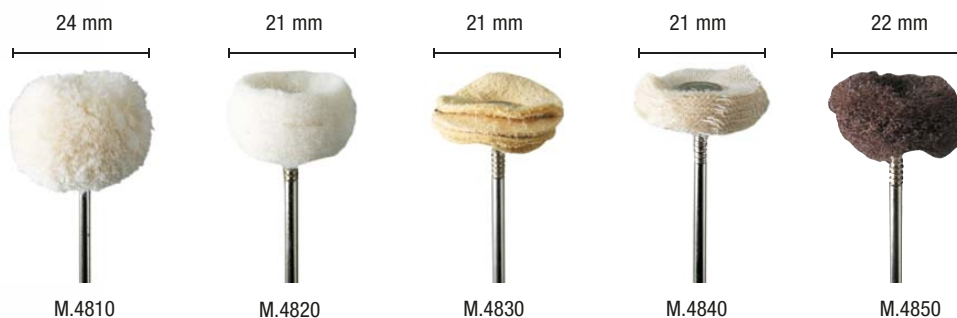

**COTTON, SOFT FELT, CHAMOIS, AND COTTON FOLDS DISCS:** for polishing metals, gold, silver, non-ferrous metals, brass, aluminium, glass

**ABRASIVE DISC SCOTCH-BRITE:** for cleaning and light sanding of steel, stainless steel and other metals, glass, wood, aluminium and plastic

<b>M.4810</b>	ø 24 mm - cotton yarn disc - shank ø 2,35 mm	5	091020
<b>M.4820</b>	ø 21 mm - soft felt disc - shank ø 2,35 mm	5	091037
<b>M.4830</b>	ø 21 mm - chamois disc - shank ø 2,35 mm	5	091044
<b>M.4840</b>	ø 21 mm - cotton folds disc - shank ø 2,35 mm	5	091051
<b>M.4850</b>	ø 22 mm - abrasive disc scotch-brite - shank ø 2,35 mm	5	091068



**POLISHING PASTE**

To be used with felt or cotton accessories. For polishing metals and plastic and removing dullness and oxidations and light surface imperfections

<b>M.4905</b>	pink pre-polishing paste - universal	5	091075
<b>M.4910</b>	white final polishing paste - universal	5	091082
<b>M.4915</b>	red lapping paste for copper, brass, bronze	5	091099



ref.

description

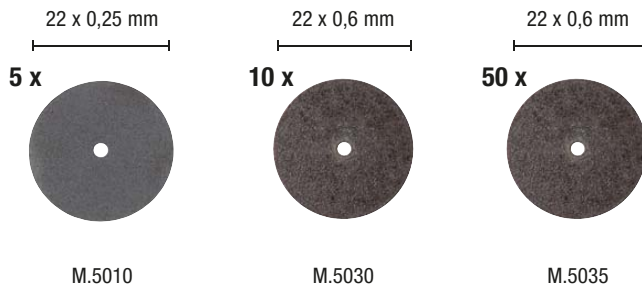
pack  
q.tyEAN13  
8011017**CUTTING  
ROUGHING****CUTTING DISCS****M.5010** For cutting and grooving glass. Suitable also for metal plates, wood and plastic**M.5030 - M.5035** For cutting and slotting bolts, screws, metal plates, thin wood and plastic

<b>M.5010</b>	5 discs ø 22 x 0,25 mm - slim	5	091105
<b>M.5030</b>	10 discs ø 22 x 0,6 mm	5	091112
<b>M.5035</b>	50 discs ø 22 x 0,6 mm	5	091129

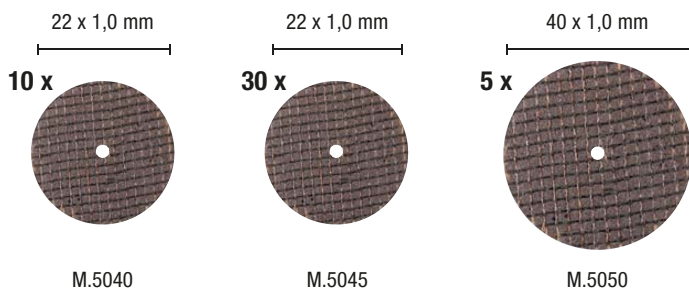
**FIBERGLASS REINFORCED CUTTING DISCS**

For cutting and slotting bolts, screws, metal plates, thin wood and plastic

<b>M.5040</b>	10 discs ø 22 x 1,0 mm	5	093680
<b>M.5045</b>	30 discs ø 22 x 1,0 mm	5	093697
<b>M.5050</b>	5 discs ø 40 x 1,0 mm	5	091136

**ROUGHING DISCS**

For roughing and slotting metal, ceramic and plastic

<b>M.5130</b>	2 discs ø 32 x 2,2 mm	5	091143
---------------	-----------------------	---	--------



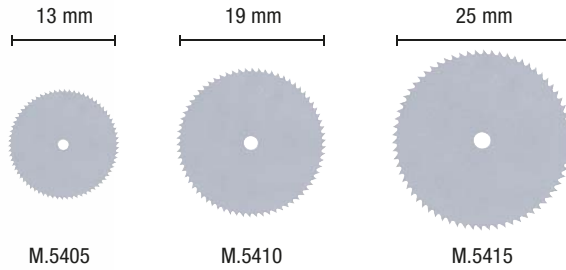

**MINI STEEL SAW BLADES**

For cutting plastic (electronic boards), wood and non ferrous metals

<b>M.5405</b>	∅ 13 mm	5	091150
<b>M.5410</b>	∅ 19 mm	5	091167
<b>M.5415</b>	∅ 25 mm	5	091174

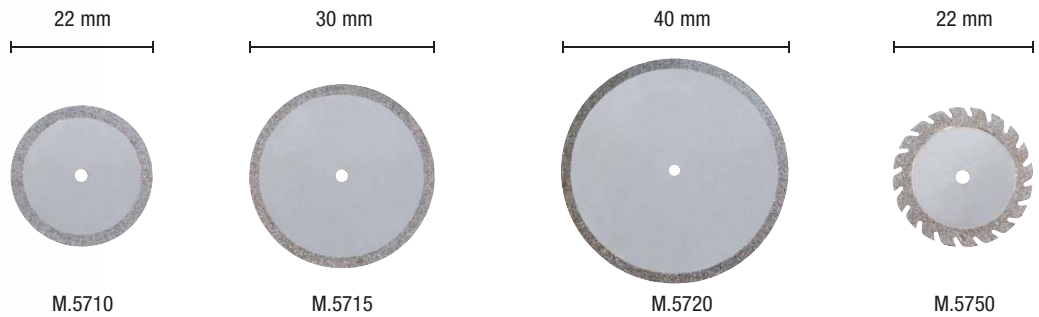

**DIAMOND DISC**

For cutting and grinding materials harder than metal, like marble, stone, porcelain, ceramic and hard resins. It allows an extreme precision while cutting and a long life

<b>M.5710</b>	∅ 22 mm	5	091181
<b>M.5715</b>	∅ 30 mm	5	093314
<b>M.5720</b>	∅ 40 mm	5	093321
<b>M.5750</b>	∅ 22 mm - segmented	5	093338

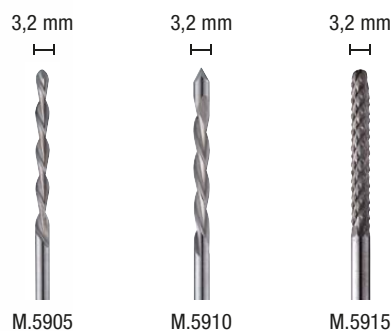

**SPIRAL CUTTING BITS**

**M.5905** For cutting wood, plastic and fiberglass

**M.5910** For cutting drywall

**M.5915** For cutting ceramic tile, plaster and cement board

<b>M.5905</b>	∅ 3,2 mm - shank ∅ 3,2 mm	5	093345
<b>M.5910</b>	∅ 3,2 mm - shank ∅ 3,2 mm	5	093352
<b>M.5915</b>	∅ 3,2 mm - shank ∅ 3,2 mm	5	093369

ref.

description

pack  
q.tyEAN13  
8011017**HSS DRILL BITS**

A complete range of HSS drill bits to hole with precision wood, metal and plastic

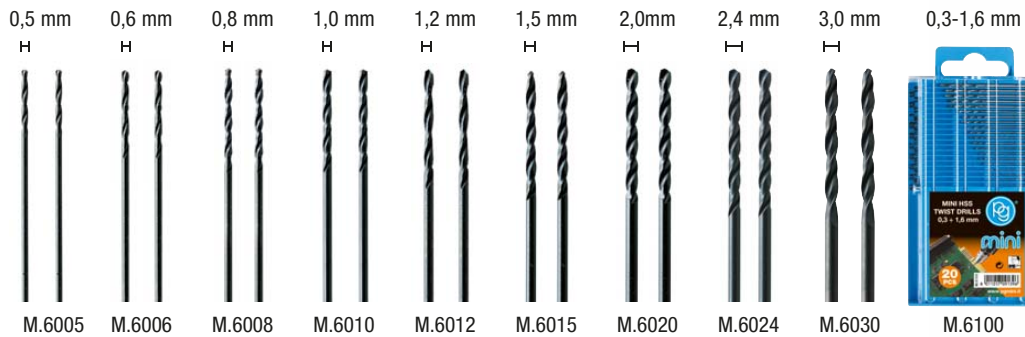
**HSS DRILL BITS**

<b>M.6005</b>	2 drill bits $\varnothing$ <b>0,5</b> mm	5	091198
<b>M.6006</b>	2 drill bits $\varnothing$ <b>0,6</b> mm	5	091204
<b>M.6008</b>	2 drill bits $\varnothing$ <b>0,8</b> mm	5	091211
<b>M.6010</b>	2 drill bits $\varnothing$ <b>1,0</b> mm	5	091228
<b>M.6012</b>	2 drill bits $\varnothing$ <b>1,2</b> mm	5	091235
<b>M.6015</b>	2 drill bits $\varnothing$ <b>1,5</b> mm	5	091242
<b>M.6020</b>	2 drill bits $\varnothing$ <b>2,0</b> mm	5	091259
<b>M.6024</b>	2 drill bits $\varnothing$ <b>2,4</b> mm	5	091266
<b>M.6030</b>	2 drill bits $\varnothing$ <b>3,0</b> mm	5	091273
<b>M.6100</b>	kit 20 drill bits $\varnothing$ <b>0,3 - 0,35 - 0,4 - 0,45 - 0,5 - 0,55 - 0,6 - 0,65 - 0,7 - 0,75 - 0,8 - 0,85 - 0,9 - 0,95 - 1,0 - 1,2 - 1,3 - 1,4 - 1,5 - 1,6</b> mm	2	091396

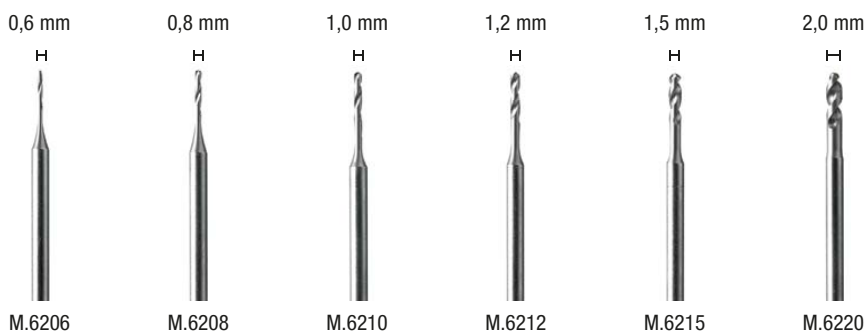
**HSS REINFORCED DRILL BITS**

<b>M.6206</b>	$\varnothing$ <b>0,6</b> mm - shank $\varnothing$ <b>2,35</b> mm	5	091280
<b>M.6208</b>	$\varnothing$ <b>0,8</b> mm - shank $\varnothing$ <b>2,35</b> mm	5	091297
<b>M.6210</b>	$\varnothing$ <b>1,0</b> mm - shank $\varnothing$ <b>2,35</b> mm	5	091303
<b>M.6212</b>	$\varnothing$ <b>1,2</b> mm - shank $\varnothing$ <b>2,35</b> mm	5	091310
<b>M.6215</b>	$\varnothing$ <b>1,5</b> mm - shank $\varnothing$ <b>2,35</b> mm	5	091327
<b>M.6220</b>	$\varnothing$ <b>2,0</b> mm - shank $\varnothing$ <b>2,35</b> mm	5	091334



1,0 mm 1,5 mm 2,35 mm 3,0 mm 3,2 mm



M.8010 (Minicraft, PG Mini, Proxxon)

0,8 mm 2,35 mm 3,0 mm 3,2 mm



M.8020 (B&D, Dremel)

**COLLETS**

<b>M.8010</b>	collets set $\varnothing$ 1,0 - 1,5 - 2,35 - 3,0 - 3,2 mm and collet nut	2	093017
<b>M.8020</b>	collets set $\varnothing$ 0,8 - 2,35 - 3,0 - 3,2 mm and collet nut	2	093024



M.8100

M.8110

M.8120

**MANDRELS**

<b>M.8100</b>	screw mandrel - shank $\varnothing$ 3,0 mm	5	091358
<b>M.8110</b>	screw reinforced mandrel - shank $\varnothing$ 2,35 mm	5	091365
<b>M.8120</b>	pyramidal mandrel - shank $\varnothing$ 3,0 mm	5	091372



**MINI STORAGE CASE FOR ACCESSORIES**

<b>M.BOX01</b>	- modular - in plastic anti-shock with anti-slip reinforcements - dimensions 16,5 x 12 x 6,5 cm	1	088228
----------------	---	---	--------

ref.

description

pack  
q.tyEAN13  
8011017

ACCESSORIES

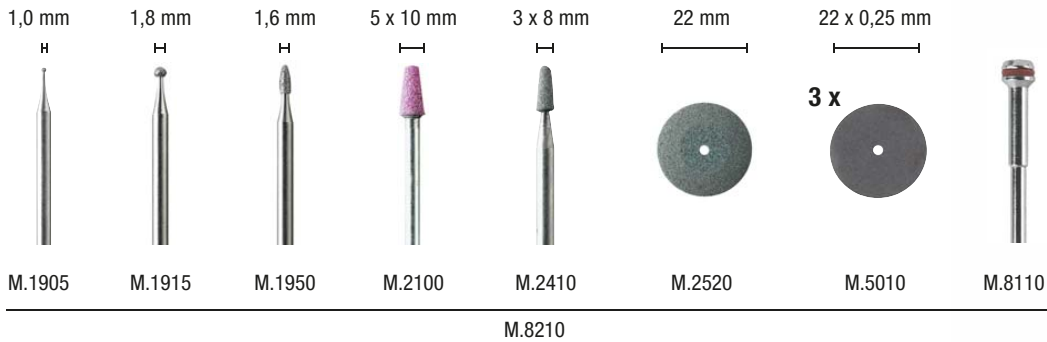
**M.8210** kit 10 accessories for engraving

2

093031

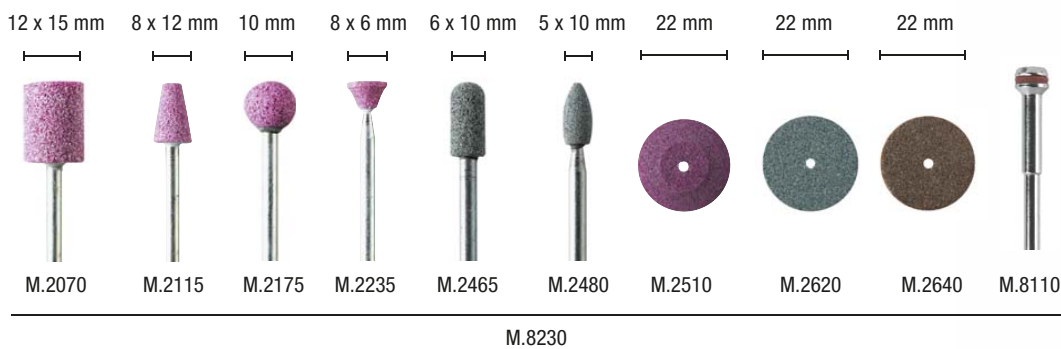
**M.8230** kit 10 accessories for grinding and sharpening

2

093048

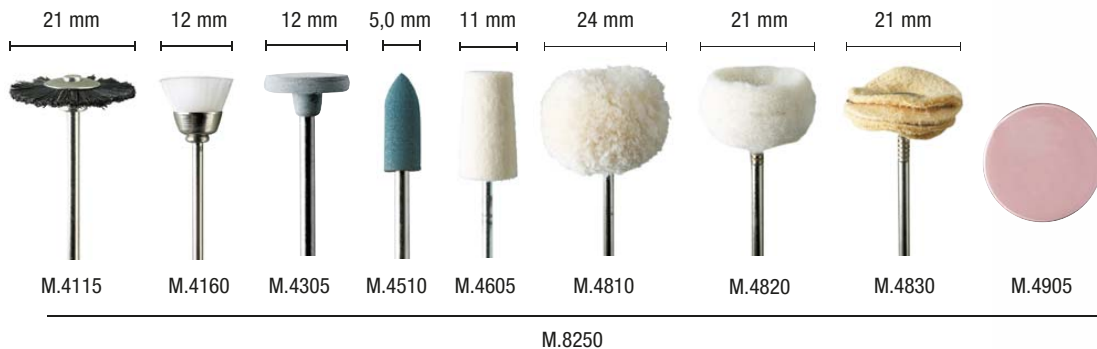
**M.8250** kit 9 accessories for cleaning and polishing

2

093055

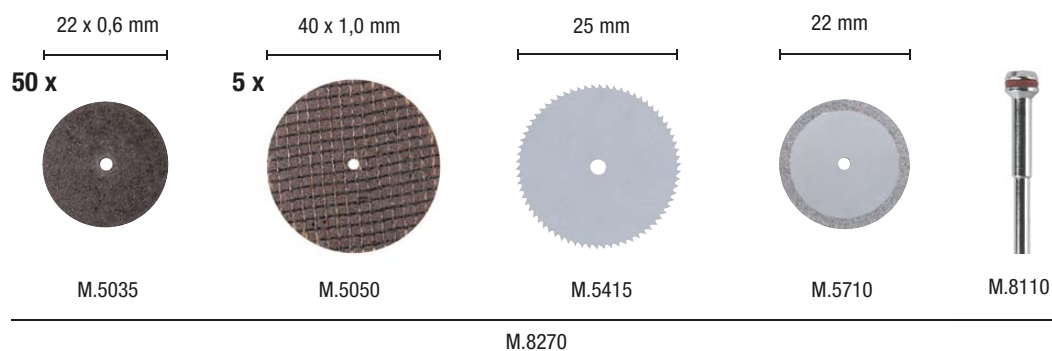
**M.8270** kit 58 accessories for cutting

2

093062





**FLEXIBLE DRIVE SHAFT** ideal for close up and detailed work

<b>M.8500</b>	- 80 cm length	1	091426
	- shank $\varnothing$ 3,0 mm		
	- with 3 assorted collets ( $\varnothing$ 2,35 - 3,0 - 3,2 mm), 1 nut and 1 wrench		
	- 30.000 RPM		



0,4-3,2 mm



M.8550 (Minicraft, PG Mini, Proxxon)

0,4-3,2 mm



M.8560 (B&D, Dremel)

**CHUCKS**

<b>M.8550</b>	keyless chuck $\varnothing$ 0,4-3,2 mm - thread 8 x 0,75 - 10.000 RPM	1	091389
<b>M.8560</b>	keyless chuck $\varnothing$ 0,4-3,2 mm - thread 9/32" x 40 - 10.000 RPM	1	093376



0,4-6,0 mm

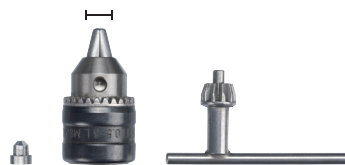

M.8580 (M.9400, M.9500, M.9600)

**CHUCKS**

<b>M.8580</b>	chuck with key and adaptor - $\varnothing$ 0,4-6,0 mm - thread 8 x 0,75 - 10.000 RPM	1	093598
---------------	--	---	--------

ref.

description

pack  
q.tyEAN13  
8011017

ACCESSORIES



### MINI DRILL STAND

**M.8600**

- multi directional tool positioning
- ideal when working with flexible shaft
- collar  $\varnothing$  43 mm + reducing collar  $\varnothing$  33 mm

1

091433



### MINI DRILL STAND

**M.8710**

- rotary collar  $\varnothing$  32/48 mm - adjustable angle and height
- toothed rack mechanism with return spring and depth stop - height 260 mm - stroke 27 mm - depth 115 mm - working height 100 mm - column  $\varnothing$  16 mm - aluminium base 250 x 180 mm

1

093666

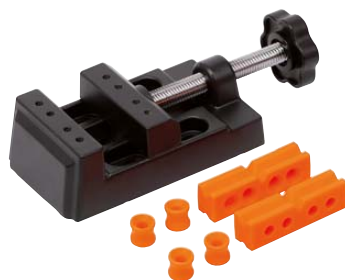

### MINI VICE

**M.8750**

- clamp width 45 mm
- max opening 50 mm

1

093383





**SCREW AND UNSCREW KIT - 45 PCS**

<b>M.8775</b>	1 flexible shaft - 1 precision tweezers 35 assorted bits - 1 screwdriver - 7 socket bits	1	093574
---------------	---	---	--------



**PRECISION CUTTERS KIT - 18 PCS**

Ideal for working on plastic, ABS panels, wood, plywood, plain paperboard or cardboard

<b>M.8790</b>	1 holder with anti-slip handle for light weight materials, quick attachment of blades 1 holder with anti-slip handle for heavy weight materials, quick attachment of blades 14 assorted precision blades 1 precision screwdriver 1 precision tweezers	1	093581
---------------	---	---	--------



Output	30 Watt
Voltage	230 V / 50 Hz
Temperature	450/500 °C
Cable length	1,2 m
Weight	94 g

**WOODBURNING PEN**

To engrave wood, cork, genuine leather, gourds, heavy weight paper, wicker and rattan

<b>M.8800</b>	- ABS body - with 2 tips (universal and conical) - with stand	1	093550
---------------	---	---	--------



**GLUE GUNS**

Nozzle with heat protection, drip block. Mechanical aid. Shockproof plastic casing. For bonding paper, plastic, wood, ceramic, textiles.



Output	<b>30 Watt</b>
Voltage	<b>230 V / 50 Hz</b>
Cable length	<b>1,8 m</b>
Weight	<b>200 g</b>

**M.8815**

- glue gun with **2** glue sticks  $\varnothing$  **7 mm**
- with ON/OFF button
- self-supporting stand

1

093703



Output	<b>60 Watt</b>
Voltage	<b>230 V / 50 Hz</b>
Cable length	<b>1,8 m</b>
Weight	<b>330 g</b>

**M.8845**

- glue gun with **2** glue sticks  $\varnothing$  **11 mm**
- with ON/OFF button
- self-supporting stand

1

093710



M.8822



M.88257

**HOT MELT GLUE STICKS****M.8822** 12 glue sticks  $\varnothing$  **7 mm** - length **100 mm**

10

600000

**M.8857** 12 glue sticks  $\varnothing$  **11 mm** - length **100 mm**

10

600208





Outputs	max <b>12 VA</b>
Voltage	<b>230 V / 50 Hz</b>
Secondary Voltage	<b>15 V DC</b>
Speed	single *
Cable length	<b>2 m</b>
Weight	<b>520 g</b>

\* Speed depends on tool used

### SINGLE SPEED TRANSFORMER

<b>M.9000</b>	- sufficient power for all <b>6, 25, 30</b> and <b>40</b> Watt tools	1	091440
	- built-in overload cut-off facility for extra safety and extended tool life		



Output	<b>6 Watt</b>
Voltage	<b>0-18 V DC</b>
No load speed	<b>0-17.000 RPM</b>
Shaft holder capacity	ø <b>2,35 mm</b>
Cable length	<b>1,8 m</b>
Weight	<b>75 g</b>

### ENGRAVING PEN

<b>M.9200</b>	- lightweight pen-styled design for comfortable handling	1	091488
	- touch sensitive ON/OFF switch for easy use		
	- simple push in/pull out shaft holder for easy accessory changeover		
	- fast rotary action for effective engraving work		
	- includes <b>1</b> diamond engraving bit		
	- available in kit form art. <b>M.9250</b>		



Output	6 Watt
Voltage	230 V / 50 Hz
No load speed	0-17.000 RPM
Shaft holder capacity	ø 2,35 mm
Cable length	1,8 m
Weight	220 g

### ENGRAVING PEN WITH TRANSFORMER

**M.9220**

- lightweight pen-styled design for comfortable handling
- touch sensitive ON/OFF switch for easy use
- simple push in/pull out shaft holder for easy accessory changeover
- fast rotary action for effective engraving work
- includes **1** diamond engraving bit
- available in kit form art. **M.9250**

1

093628



### ENGRAVING KIT 6 W

**M.9250**

- **M.9200** engraving pen
- plug in transformer
- **1** diamond bit
- **3** grinding stones
- **2** stencils
- handy carry and storage case

1

091495



Output	<b>30 Watt</b>
Voltage	<b>0-18 V DC</b>
No load speed	<b>0-30.000 RPM</b>
Chuck type	keyless
Chuck capacity	Ø <b>0,4-3,2 mm</b>
Cable length	<b>1,8 m</b>
Weight	<b>125 g</b>

**HIGH TORQUE ROTARY TOOL**

<b>M.9100</b>	<ul style="list-style-type: none"> <li>- keyless chuck for easy accessory changeover</li> <li>- high speed for a variety of applications</li> <li>- pencil grip for an easy use</li> <li>- includes <b>3</b> assorted collets (Ø <b>2,35 - 3,0 - 3,2 mm</b>) and <b>1</b> nut</li> <li>- available in kit form art. <b>M.9150</b></li> </ul>	<b>1</b>	091464



**MINI ROTARY TOOL KIT 30 W**

<b>M.9150</b>	<ul style="list-style-type: none"> <li>- <b>M.9100</b> high torque rotary tool</li> <li>- <b>M.9000</b> single speed transformer</li> <li>- <b>29</b> assorted accessories</li> <li>- handy carry and storage case</li> </ul>	<b>1</b>	091471

ref.

description

pack  
q.tyEAN13  
8011017**TOOLS  
TRANSFORMERS  
KITS**

Output	<b>130 Watt</b>
Voltage	<b>230 V / 50 Hz</b>
No load speed	<b>8.000-32.000 RPM</b>
Chuck type	keyless
Chuck capacity	Ø <b>0,4-3,2 mm</b>
Cable length	<b>1,9 m</b>
Weight	<b>630 g</b>

**HIGH TORQUE ROTARY TOOL****M.9500**

- keyless chuck for easy accessory changeover
- ergonomically designed housing for comfortable gripping
- powerful motor and variable speed for increased versatility
- includes **3** assorted collets (Ø **2,35 - 3,0 - 3,2 mm**) and **1** nut
- no need of transformer or adaptors
- available in kit form art. **M.9550**

1

093116

**HIGH TORQUE ROTARY TOOL KIT 130 W****M.9550**

- **M.9500** variable speed high torque tool
- **65** assorted accessories
- handy carry and storage case

1

093123



Output	<b>170 Watt</b>
Voltage	<b>230 V / 50 Hz</b>
No load speed	<b>8.000-32.000 RPM</b>
Chuck type	keyless
Chuck capacity	ø <b>0,4-3,2 mm</b>
Cable length	<b>1,9 m</b>
Weight	<b>665 g</b>



**HIGH TORQUE ROTARY TOOL**

<b>M.9600</b>	<ul style="list-style-type: none"> <li>- keyless chuck for easy accessory changeover</li> <li>- LCD display/speed control: for more accurate working on different materials</li> <li>- ergonomically designed housing for comfortable gripping</li> <li>- powerful motor and variable speed for increased versatility</li> <li>- includes <b>3</b> assorted collets (ø <b>2,35 - 3,0 - 3,2 mm</b>) and <b>1</b> nut</li> <li>- no need of transformer or adaptors</li> <li>- available in kit form art. <b>M.9650</b></li> </ul>	<b>1</b>	093413
---------------	--	----------	--------



**HIGH TORQUE ROTARY TOOL KIT LCD DISPLAY 170 W**

<b>M.9650</b>	<ul style="list-style-type: none"> <li>- <b>M.9600</b> variable speed high torque tool with LCD display</li> <li>- <b>60</b> assorted accessories</li> <li>- handy carry and storage case</li> </ul>	<b>1</b>	093420
---------------	--	----------	--------

ref.

description

pack  
q.tyEAN13  
8011017
**TOOLS  
TRANSFORMERS  
KITS**

Output	<b>170 Watt</b>
Voltage	<b>230 V / 50 Hz</b>
No load speed	<b>8.000-35.000 RPM</b>
Chuck type	collets
Chuck capacity	max $\varnothing$ <b>3,2 mm</b>
Cable length	<b>1,7 m</b>
Weight	<b>700 g</b>

### HIGH TORQUE ROTARY TOOL

**M.9700**

- ergonomically designed housing for comfortable gripping
- rubberized body
- powerful motor and variable speed for increased versatility
- includes **3** assorted collets ( $\varnothing$  **2,35 - 3,0 - 3,2 mm**), **1** nut and **1** wrench
- compatible with keyless chuck art. **M.8550**
- no need of transformer or adaptors
- available in kit form art. **M.9750**

**1**

093765



### HIGH TORQUE ROTARY TOOL KIT 170 W

**M.9750**

- **M.9700** variable speed high torque tool
- **80** assorted accessories
- handy carry and storage case

**1**

093772

DISPLAYER

<b>ESPO.M4A</b>	<b>displayer:</b> - height <b>82</b> cm - width <b>46</b> cm - depth <b>32</b> cm	1	093789
<b>ESPO.M4C</b>	<b>wall displayer:</b> - height <b>206</b> cm - width <b>100</b> cm - depth <b>40</b> cm	1	093802

Standard layout of displayers is flexible and adaptable to any requirement.



ESPO.M4A

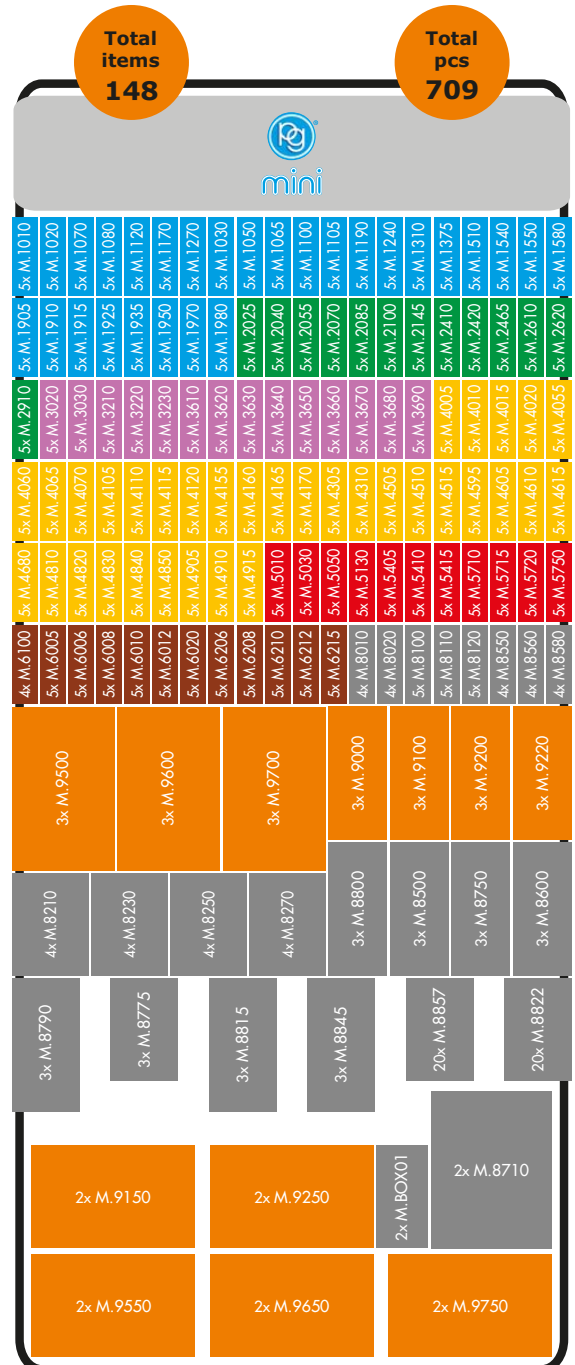

ESPO.M4C



# INDEX: REFERENCES, QUANTITIES AND BAR CODES

## Place number 8011017 before EAN code

ref.	description	☐	ean	page	ref.	description	☐	ean	page
10.010	2 HSS DRILL BITS 1 MM	10	100104	87	13.555	BIMETAL HOLE SAW 30MM	1	135557	74
10.015	2 HSS DRILL BITS 1,5 MM	10	100159	87	13.560	BIMETAL HOLE SAW 32MM	1	135601	74
10.020	2 HSS DRILL BITS 2 MM	10	100203	87	13.565	BIMETAL HOLE SAW 33MM	1	135656	74
10.025	2 HSS DRILL BITS 2,5 MM	10	100258	87	13.570	BIMETAL HOLE SAW 35MM	1	135700	74
10.030	2 HSS DRILL BITS 3 MM	10	100302	87	13.575	BIMETAL HOLE SAW 37MM	1	135755	74
10.035	2 HSS DRILL BITS 3,5 MM	10	100357	87	13.580	BIMETAL HOLE SAW 38MM	1	135809	74
10.040	2 HSS DRILL BITS 4 MM	10	100401	87	13.585	BIMETAL HOLE SAW 40MM	1	135854	74
10.045	HSS DRILL BIT 4,5 MM	10	100456	87	13.590	BIMETAL HOLE SAW 41MM	1	135908	74
10.050	HSS DRILL BIT 5 MM	10	100500	87	13.595	BIMETAL HOLE SAW 43MM	1	135953	74
10.055	HSS DRILL BIT 5,5 MM	10	100555	87	13.600	BIMETAL HOLE SAW 44MM	1	136004	74
10.060	HSS DRILL BIT 6 MM	10	100609	87	13.605	BIMETAL HOLE SAW 46MM	1	136059	74
10.065	HSS DRILL BIT 6,5 MM	10	100654	87	13.610	BIMETAL HOLE SAW 48MM	1	136103	74
10.070	HSS DRILL BIT 7 MM	10	100708	87	13.615	BIMETAL HOLE SAW 51MM	1	136158	74
10.075	HSS DRILL BIT 7,5 MM	10	100753	87	13.620	BIMETAL HOLE SAW 52MM	1	136202	74
10.080	HSS DRILL BIT 8 MM	10	100807	87	13.625	BIMETAL HOLE SAW 54MM	1	136257	74
10.085	HSS DRILL BIT 8,5 MM	10	100852	87	13.630	BIMETAL HOLE SAW 57MM	1	136301	74
10.090	HSS DRILL BIT 9 MM	10	100906	87	13.635	BIMETAL HOLE SAW 59MM	1	136356	74
10.095	HSS DRILL BIT 9,5 MM	10	100951	87	13.640	BIMETAL HOLE SAW 60MM	1	136400	74
10.100	HSS DRILL BIT 10 MM	10	101002	87	13.645	BIMETAL HOLE SAW 64MM	1	136455	74
10.105	HSS DRILL BIT 10,5MM	10	101057	87	13.650	BIMETAL HOLE SAW 65MM	1	136509	74
10.110	HSS DRILL BIT 11 MM	10	101101	87	13.655	BIMETAL HOLE SAW 67MM	1	136554	74
10.115	HSS DRILL BIT 11,5MM	10	101156	87	13.660	BIMETAL HOLE SAW 70MM	1	136608	74
10.120	HSS DRILL BIT 12 MM	10	101200	87	13.665	BIMETAL HOLE SAW 73MM	1	136653	74
10.125	HSS DRILL BIT 12,5MM	10	101255	87	13.670	BIMETAL HOLE SAW 76MM	1	136707	74
10.130	HSS DRILL BIT 13 MM	10	101309	87	13.675	BIMETAL HOLE SAW 79MM	1	136752	74
103.1/4	TAP RE-SEATING TOOL 1/2	10	103143	10	13.680	BIMETAL HOLE SAW 83MM	1	136806	74
103.6MA	TAP RE-SEATING TOOL 1/2	10	103006	10	13.685	BIMETAL HOLE SAW 86MM	1	136851	74
11.010	CUTTER 10MM 6MA	10	110103	11	13.690	BIMETAL HOLE SAW 89MM	1	136905	74
11.012	CUTTER 12MM 6MA	10	110127	11	13.695	BIMETAL HOLE SAW 92MM	1	136950	74
11.014	CUTTER 14MM 6MA 3/8	10	110141	11	13.700	BIMETAL HOLE SAW 95MM	1	137001	74
11.017	CUTTER 17MM 6MA 1/2	10	110172	11	13.705	BIMETAL HOLE SAW 98MM	1	137056	74
11.024	CUTTER 24MM 6MA 3/4	10	110240	11	13.710	BIMETAL HOLE SAW 102MM	1	137100	74
11.028	CUTTER 28MM 6MA 1"	10	110288	11	13.715	BIMETAL HOLE SAW 105MM	1	137155	74
11.034	CUTTER 34MM 1/4 1"1/8"	5	110349	11	13.720	BIMETAL HOLE SAW 108MM	1	137209	74
11.038	CUTTER 38MM 1/4 1"1/4	5	110387	11	13.725	BIMETAL HOLE SAW 111MM	1	137254	74
11.043	CUTTER 43MM 1/4 1"1/2	5	110431	11	13.730	BIMETAL HOLE SAW 114MM	1	137308	74
11.055	CUTTER 55MM 1/4 2"	5	110554	11	13.735	BIMETAL HOLE SAW 121MM	1	137353	74
12.010	FORSTNER BIT 10MM	1	120102	42	13.740	BIMETAL HOLE SAW 127MM	1	137407	74
12.012	FORSTNER BIT 12MM	1	120126	42	13.745	BIMETAL HOLE SAW 140MM	1	137452	74
12.014	FORSTNER BIT 14MM	1	120140	42	13.750	BIMETAL HOLE SAW 152MM	1	137506	74
12.015	FORSTNER BIT 15MM	1	120157	42	13.780	BIMETAL ARBOR 14/30MM	1	137803	73
12.016	FORSTNER BIT 16MM	1	120164	42	13.785	BIMETAL ARBOR 32/152MM	1	137858	73
12.018	FORSTNER BIT 18MM	1	120188	42	13.790	BIMETAL ARBOR 14/30MM	1	137902	73
12.020	FORSTNER BIT 20MM	1	120201	42	13.795	BIMETAL ARBOR 32/152MM	1	137957	73
12.022	FORSTNER BIT 22MM	1	120225	42	13.800	DRILL FOR BIMETAL ARBOR 115MM	1	138008	73
12.024	FORSTNER BIT 24MM	1	120249	42	13.805	DRILL FOR BIMETAL ARBOR 70MM	1	138053	73
12.025	FORSTNER BIT 25MM	1	120256	42	14.003	WOOD DRILL BIT 3MM BULK	10	140032	89
12.026	FORSTNER BIT 26MM	1	120263	42	14.004	WOOD DRILL BIT 4MM BULK	10	140049	89
12.028	FORSTNER BIT 28MM	1	120287	42	14.005	WOOD DRILL BIT 5MM BULK	10	140056	89
12.030	FORSTNER BIT 30MM	1	120300	42	14.006	WOOD DRILL BIT 6MM BULK	10	140063	89
12.032	FORSTNER BIT 32MM	1	120324	42	14.007	WOOD DRILL BIT 7MM BULK	10	140070	89
12.034	FORSTNER BIT 34MM	1	120348	42	14.008	WOOD DRILL BIT 8MM BULK	10	140087	89
12.035	FORSTNER BIT 35MM	1	120355	42	14.009	WOOD DRILL BIT 9MM BULK	10	140094	89
12.036	FORSTNER BIT 36MM	1	120362	42	14.010	WOOD DRILL BIT 10MM BULK	10	140100	89
12.040	FORSTNER BIT 40MM	1	120409	42	14.011	WOOD DRILL BIT 11MM BULK	10	140117	89
12.045	FORSTNER BIT 45MM	1	120454	42	14.012	WOOD DRILL BIT 12MM BULK	10	140124	89
12.050	FORSTNER BIT 50MM	1	120508	42	14.013	WOOD DRILL BIT 13MM BULK	10	140131	89
13.500	BIMETAL HOLE SAW 14MM	1	135007	74	14.014	WOOD DRILL BIT 14MM BULK	10	140148	89
13.505	BIMETAL HOLE SAW 16MM	1	135052	74	14.015	WOOD DRILL BIT 15MM BULK	10	140155	89
13.510	BIMETAL HOLE SAW 17MM	1	135106	74	14.016	WOOD DRILL BIT 16MM BULK	10	140162	89
13.515	BIMETAL HOLE SAW 19MM	1	135151	74	14.018	WOOD DRILL BIT 18MM BULK	5	140186	89
13.520	BIMETAL HOLE SAW 20MM	1	135205	74	14.020	WOOD DRILL BIT 20MM BULK	5	140209	89
13.525	BIMETAL HOLE SAW 21MM	1	135250	74	14.022	WOOD DRILL BIT 22MM BULK	5	140223	89
13.530	BIMETAL HOLE SAW 22MM	1	135304	74	14.024	WOOD DRILL BIT 24MM BULK	5	140247	89
13.535	BIMETAL HOLE SAW 24MM	1	135359	74	14.026	WOOD DRILL BIT 26MM BULK	2	140261	89
13.540	BIMETAL HOLE SAW 25MM	1	135403	74	14.028	WOOD DRILL BIT 28MM BULK	2	140285	89
13.545	BIMETAL HOLE SAW 27MM	1	135458	74	14.030	WOOD DRILL BIT 30MM BULK	2	140308	89
13.550	BIMETAL HOLE SAW 29MM	1	135502	74	14.206	WOOD DRILL BIT 6X250MM	1	142067	89

# INDEX: REFERENCES, QUANTITIES AND BAR CODES

## Place number 8011017 before EAN code

ref.	description	☐	ean	page	ref.	description	☐	ean	page
14.207	WOOD DRILL BIT 7X250MM	1	142074	89	17.025	HSS DRILL BIT 2,5 MM BULK	10	170251	87
14.208	WOOD DRILL BIT 8X250MM	1	142081	89	17.030	HSS DRILL BIT 3 MM BULK	10	170305	87
14.209	WOOD DRILL BIT 9X250MM	1	142098	89	17.035	HSS DRILL BIT 3,5 MM BULK	10	170350	87
14.210	WOOD DRILL BIT 10X250MM	1	142104	89	17.040	HSS DRILL BIT 4 MM BULK	10	170404	87
14.211	WOOD DRILL BIT 11X250MM	1	142111	89	17.045	HSS DRILL BIT 4,5 MM BULK	10	170459	87
14.212	WOOD DRILL BIT 12X250MM	1	142128	89	17.050	HSS DRILL BIT 5 MM BULK	10	170503	87
14.213	WOOD DRILL BIT 13X250MM	1	142135	89	17.055	HSS DRILL BIT 5,5 MM BULK	10	170558	87
14.214	WOOD DRILL BIT 14X250MM	1	142142	89	17.060	HSS DRILL BIT 6 MM BULK	10	170602	87
14.215	WOOD DRILL BIT 15X250MM	1	142159	89	17.065	HSS DRILL BIT 6,5 MM BULK	10	170657	87
14.216	WOOD DRILL BIT 16X250MM	1	142166	89	17.070	HSS DRILL BIT 7 MM BULK	10	170701	87
14.218	WOOD DRILL BIT 18X250MM	1	142180	89	17.075	HSS DRILL BIT 7,5 MM BULK	10	170756	87
14.220	WOOD DRILL BIT 20X250MM	1	142203	89	17.080	HSS DRILL BIT 8 MM BULK	10	170800	87
14.222	WOOD DRILL BIT 22X250MM	1	142227	89	17.085	HSS DRILL BIT 8,5 MM BULK	10	170855	87
14.224	WOOD DRILL BIT 24X250MM	1	142241	89	17.090	HSS DRILL BIT 9 MM BULK	10	170909	87
15.030	MASONRY DRILL BIT 3MM	10	150307	88	17.095	HSS DRILL BIT 9,5 MM BULK	10	170954	87
15.040	MASONRY DRILL BIT 4MM	10	150406	88	17.100	HSS DRILL BIT 10 MM BULK	10	171005	87
15.050	MASONRY DRILL BIT 5MM	10	150505	88	17.105	HSS DRILL BIT 10,5MM BULK	10	171050	87
15.060	MASONRY DRILL BIT 6MM	10	150604	88	17.110	HSS DRILL BIT 11 MM BULK	10	171104	87
15.070	MASONRY DRILL BIT 7MM	10	150703	88	17.115	HSS DRILL BIT 11,5MM BULK	10	171159	87
15.080	MASONRY DRILL BIT 8MM	10	150802	88	17.120	HSS DRILL BIT 12 MM BULK	10	171203	87
15.090	MASONRY DRILL BIT 9MM	10	150901	88	17.125	HSS DRILL BIT 12,5MM BULK	10	171258	87
15.100	MASONRY DRILL BIT 10MM	10	151007	88	17.130	HSS DRILL BIT 13 MM BULK	10	171302	87
15.120	MASONRY DRILL BIT 12MM	10	151205	88	17.135	HSS DRILL BIT 13,5MM BULK	5	171357	87
15.140	MASONRY DRILL BIT 14MM	10	151403	88	17.140	HSS DRILL BIT 14 MM BULK	5	171401	87
15.606	SET 5 WOOD DRILLS 4/10MM	2	156064	86	17.145	HSS DRILL BIT 14,5MM BULK	5	171456	87
15.607	SET 8 WOOD DRILLS 3/10MM	2	156071	86	17.150	HSS DRILL BIT 15 MM BULK	5	171500	87
15.608	SET 5 MASONRY DRILLS 4/10MM	2	156088	86	17.155	HSS DRILL BIT 15,5MM BULK	5	171555	87
15.610	SET 8 MASONRY DRILLS 3/10MM	2	156101	86	17.160	HSS DRILL BIT 16 MM BULK	5	171609	87
15.615	SET 13 HSS TW.DRILLS 1,5/6,5MM	2	156156	86	201.1/4	TAP RE-SEATING TOOL 3/8-1"	1	201146	10
15.620	SET 13 HSS TWIST DRILLS 2/8MM	2	156200	86	201.6MA	TAP RE-SEATING TOOL 3/8-1"	1	201009	10
15.630	SET 9 MASONRY-HSS DRILLS	2	156309	86	202.1/4	TAP RE-SEATING TOOL 3/8-1"	1	202143	10
15.640	SET 9 HSS-WOOD-MASONRY DRILLS	2	156408	86	202.6MA	TAP RE-SEATING TOOL 3/8-1"	1	202006	10
16.030	MASONRY DRILL BIT 3MM BULK	10	160306	88	203.6MA	TAP RE-SEATING TOOL 1/2-3/4	1	203003	10
16.040	MASONRY DRILL BIT 4MM BULK	10	160405	88	204.1/4	TAP RE-SEATING TOOL 1"1/8-2"	1	204147	10
16.050	MASONRY DRILL BIT 5MM BULK	10	160504	88	205.6MA	TAP RE-SEATING TOOL 3/8-1"	1	205007	10
16.055	MASONRY DRILL BIT 5,5MM BULK	10	160559	88	207.6MA	TAP RE-SEATING TOOL 3/8-1"	1	207001	10
16.060	MASONRY DRILL BIT 6MM BULK	10	160603	88	208.6MA	TAP RE-SEATING TOOL 10-16MM	1	208008	10
16.065	MASONRY DRILL BIT 6,5MM BULK	10	160658	88	209.6MA	TAP RE-SEATING TOOL 13-16MM	1	209005	10
16.070	MASONRY DRILL BIT 7MM BULK	10	160702	88	210.6MA	TAP RE-SEATING TOOL 3/8-1"	1	210001	11
16.080	MASONRY DRILL BIT 8MM BULK	10	160801	88	212.1/4	TAP RE-SEATING TOOL 3/8-1/2	10	212142	10
16.090	MASONRY DRILL BIT 9MM BULK	10	160900	88	212.6MA	TAP RE-SEATING TOOL 3/8-1/2	10	212005	10
16.100	MASONRY DRILL BIT 10MM BULK	10	161006	88	213.6MA	TAP RE-SEATING TOOL 3/8-1/2	10	213002	11
16.110	MASONRY DRILL BIT 11MM BULK	10	161105	88	214.00	HOLE CUTTER 20/123MM	5	214009	13
16.120	MASONRY DRILL BIT 12MM BULK	10	161204	88	214.10	HSS CUTTING TOOL 5MM 214.00	5	214108	13
16.130	MASONRY DRILL BIT 13MM BULK	10	161303	88	215.00	HOLE CUTTER 25/217MM	5	215006	13
16.140	MASONRY DRILL BIT 14MM BULK	10	161402	88	215.10	HSS CUTTING TOOL 6MM 215.00	5	215105	13
16.150	MASONRY DRILL BIT 15MM BULK	10	161501	88	216.00	HOLE CUTTER 27/104MM	5	216003	13
16.160	MASONRY DRILL BIT 16MM BULK	10	161600	88	216.10	HSS CUTTING TOOL 5MM 216.00	5	216102	13
16.180	MASONRY DRILL BIT 18MM BULK	5	161808	88	217.00	TILE CUTTER 30/100MM	1	217000	73
16.200	MASONRY DRILL BIT 20MM BULK	5	162003	88	217.10	CUTTING TOOL FOR ART. 217.00	1	217109	73
16.408	MASONRY DRILL BIT 8X400MM	1	164083	88	218.00	CONE-SHAPED NUT 14MA	10	218007	14
16.410	MASONRY DRILL BIT 10X400MM	1	164106	88	219.00	FLAT NUT 14MA	10	219004	14
16.412	MASONRY DRILL BIT 12X400MM	1	164120	88	220.00	CONE-SHAPED NUT 8MA BULK	10	220000	14
16.414	MASONRY DRILL BIT 14X400MM	1	164144	88	220.50	CONE-SHAPED NUT 10MA COL.16 B	10	220505	14
16.416	MASONRY DRILL BIT 16X400MM	1	164168	88	221.00	CONE-SHAPED NUT 10MA BULK	10	221007	14
16.418	MASONRY DRILL BIT 18X400MM	1	164182	88	222.00	CONE-SHAPED NUT 14MA BULK	10	222004	14
16.420	MASONRY DRILL BIT 20X400MM	1	164205	88	223.00	CONE-SHAPED NUT 5/8 BULK	10	223001	14
16.422	MASONRY DRILL BIT 22X400MM	1	164229	88	224.00	FLAT NUT 8MA BULK	10	224008	14
16.425	MASONRY DRILL BIT 25X400MM	1	164250	88	225.00	FLAT NUT 10MA BULK	10	225005	14
16.610	MASONRY DRILL BIT 10X600MM	1	166100	88	226.00	FLAT NUT 14MA BULK	10	226002	14
16.612	MASONRY DRILL BIT 12X600MM	1	166124	88	227.00	FLAT NUT 5/8 BULK	10	227009	14
16.614	MASONRY DRILL BIT 14X600MM	1	166148	88	228.00	STEEL UNIVERSAL WRENCH 35MM	10	228006	14
16.616	MASONRY DRILL BIT 16X600MM	1	166162	88	229.00	STEEL UNIVERSAL WRENCH 35 BULK	10	229003	14
16.618	MASONRY DRILL BIT 18X600MM	1	166186	88	230.00	ADJU. STEEL UNIV. WRENCH 20/35	10	230009	14
16.620	MASONRY DRILL BIT 20X600MM	1	166209	88	231.00	ADJU. STEEL UNIV. WRENCH 20/35	10	231006	14
17.010	HSS DRILL BIT 1 MM BULK	10	170107	87	230.00	ADJU. STEEL UNIV. WRENCH 20/35	10	231006	14
17.015	HSS DRILL BIT 1,5 MM BULK	10	170152	87	250.00	BACK NUT FOR DISC 115MM	1	250007	14
17.020	HSS DRILL BIT 2 MM BULK	10	170206	87	253.00	BACK NUT FOR DISC 230MM	1	253008	14
					305.00	LAVABO WRENCH	5	305004	11

# INDEX: REFERENCES, QUANTITIES AND BAR CODES

## Place number 8011017 before EAN code

ref.	description	☐	ean	page	ref.	description	☐	ean	page
316.00	16MM PIPE CUTTER	5	316000	11	348.35	5 VELCRO ABRASIVE SHEETS 60	10	348353	21
333.00	UNIVERSAL CUTTING WHEEL	10	333007	11	348.36	25 VELCRO ABRASIVE SHEETS 60	1	348360	21
335.00	ARBOR 10X6MM	10	335001	14	348.40	5 VELCRO ABRASIVE SHEETS 80	10	348407	21
336.00	ARBOR 12,8X8MM	10	336008	14	348.41	25 VELCRO ABRASIVE SHEETS 80	1	348414	21
337.00	ARBOR 22,2X8MM	10	337005	14	348.45	5 VELCRO ABRASIVE SHEETS 120	10	348452	21
338.00	RUBBER BACKING PAD 125MM	10	338002	15	348.46	25 VELCRO ABRASIVE SHEETS 120	1	348469	21
338.05	RUBBER BACKING PAD 180MM	10	338057	15	348.50	5 VELCRO ABRASIVE SHEETS 240	10	348506	21
338.08	RUBBER BACKING PAD 180MM BULK	10	338088	15	348.51	25 VELCRO ABRASIVE SHEETS 240	1	348513	21
338.10	NYLON BACKING PAD 100X10MM	10	338101	15	348.56	25 VELCRO ABRASIVE SHEETS ASS.	1	348568	21
338.20	NYLON BACKING PAD 115X14MM	10	338200	15	349.00	10 VELCRO ABR. DISCS 115 G. 40	10	349008	21
338.22	NYLON BACKING PAD 178X14MM	10	338224	15	349.01	25 VELCRO ABR. DISCS 115 G. 40	1	349015	21
338.25	NYLON BACKING PAD 100X10 BULK	10	338255	15	349.10	10 VELCRO ABR. DISCS 115 G.120	10	349107	21
338.30	NYLON BACKING PAD 115X10 BULK	10	338309	15	349.11	25 VELCRO ABR. DISCS 115 G.120	1	349114	21
338.35	NYLON BACKING PAD 115X14 BULK	10	338354	15	349.20	10 VELCRO ABR. DISCS 115 G.240	10	349206	21
338.40	NYLON BACKING PAD 115X16 BULK	10	338408	15	349.21	25 VELCRO ABR. DISCS 115 G.240	1	349213	21
338.45	NYLON BACKING PAD 125X14 BULK	10	338453	15	349.30	10 VELCRO ABR. DISCS 115 G.ASS	10	349305	21
338.50	NYLON BACKING PAD 125X16 BULK	10	338507	15	349.31	25 VELCRO ABR. DISCS 115 G.ASS	1	349312	21
338.55	NYLON BACKING PAD 150X14 BULK	10	338552	15	349.33	10 VELCRO ABR. DISCS 115 G. 40	10	349336	22
338.60	NYLON BACKING PAD 150X16 BULK	10	338606	15	349.34	25 VELCRO ABR. DISCS 115 G. 40	1	349343	22
338.65	NYLON BACKING PAD 178X14 BULK	10	338651	15	349.35	10 VELCRO ABR. DISCS 115 G. 80	10	349350	22
338.70	NYLON BACKING PAD 178X16 BULK	10	338705	15	349.36	25 VELCRO ABR. DISCS 115 G. 80	1	349367	22
338.80	VELCRO BACKING PAD 115MM M14	5	338804	15	349.40	10 VELCRO ABR. DISCS 115 G.120	10	349404	22
338.82	VELCRO BACKING PAD 125MM M14	5	338828	15	349.41	25 VELCRO ABR. DISCS 115 G.120	1	349411	22
338.85	VELCRO BACKING PAD 150MM M14	5	338859	15	349.45	10 VELCRO ABR. DISCS 115 G.240	10	349459	22
339.00	LAMBSWOOL BONNET 140MM	10	339009	16	349.46	25 VELCRO ABR. DISCS 115 G.240	1	349466	22
339.20	LAMBSWOOL BONNET 190MM	10	339207	16	349.50	10 VELCRO ABR. DISCS 115 G.ASS	10	349503	22
339.22	VELCRO LAMBSWOOL BONNET 115MM	10	339221	16	349.51	25 VELCRO ABR. DISCS 115 G.ASS	1	349510	22
339.23	VELCRO LAMBSWOOL BONNET 125MM	10	339238	16	349.55	10 VELCRO ABR. DISCS 125 G. 40	10	349558	21
339.24	VELCRO LAMBSWOOL BONNET 160MM	10	339245	16	349.56	25 VELCRO ABR. DISCS 125 G. 40	1	349565	21
339.25	FELT BUFFING DISC 80X10MM	10	339252	16	349.60	10 VELCRO ABR. DISCS 125 G.120	10	349602	21
339.26	VELCRO FELT BUFFING DISC 125MM	10	339269	16	349.61	25 VELCRO ABR. DISCS 125 G.120	1	349619	21
339.27	FELT BUFFING DISC 125X15MM	10	339276	16	349.65	10 VELCRO ABR. DISCS 125 G.240	10	349657	21
339.28	FELT BUFFING DISC 150X20MM	10	339283	16	349.66	25 VELCRO ABR. DISCS 125 G.240	1	349664	21
339.29	VELCRO FELT POLISHING PAD 93MM	10	339290	16	349.70	10 VELCRO ABR. DISCS 125 G.ASS	10	349701	21
339.30	COTTON BUFFING WHEEL 80MM	10	339306	16	349.71	25 VELCRO ABR. DISCS 125 G.ASS	1	349718	21
339.35	COTTON BUFFING WHEEL 100MM	10	339351	16	349.73	10 VELCRO ABR. DISCS 125 G. 40	10	349732	22
339.40	COTTON BUFFING WHEEL 120MM	10	339405	16	349.74	25 VELCRO ABR. DISCS 125 G. 40	1	349749	22
339.45	COTTON BUFFING WHEEL 150MM	10	339450	16	349.75	10 VELCRO ABR. DISCS 125 G. 80	10	349756	22
339.46	COTTON AND SISAL WHEEL 80MM	10	339467	17	349.76	25 VELCRO ABR. DISCS 125 G. 80	1	349763	22
339.49	COTTON AND SISAL WHEEL 150MM	10	339498	17	349.80	10 VELCRO ABR. DISCS 125 G.120	10	349800	22
339.50	POLISHING CUSHION PAD 125MM	1	339504	17	349.81	25 VELCRO ABR. DISCS 125 G.120	1	349817	22
339.60	POLISHING CUSHION PAD 175MM 14	1	339603	17	349.85	10 VELCRO ABR. DISCS 125 G.240	10	349855	22
339.62	POLISHING CUSHION PAD 125MM	1	339627	17	349.86	25 VELCRO ABR. DISCS 125 G.240	1	349862	22
339.64	POLISHING CUSHION PAD 175MM	1	339641	17	349.90	10 VELCRO ABR. DISCS 125 G.ASS	10	349909	22
339.66	VELCRO POLISH.CUSHION PAD 115M	1	339665	17	349.91	25 VELCRO ABR. DISCS 125 G.ASS	1	349916	22
339.67	VELCRO POLISH.CUSHION PAD 125M	1	339672	17	349.95	10 VELCRO ABR. DISCS 150 G. 40	10	349954	22
339.68	VELCRO POLISH.CUSHION PAD 160M	1	339689	17	349.96	10 VELCRO ABR. DISCS 150 G. 80	10	349961	22
339.70	SMOOTHING BLOCK 125X70MM	10	339702	19	349.97	10 VELCRO ABR. DISCS 150 G.120	10	349978	22
339.72	SMOOTHING BLOCK 125X70 VELCRO	5	339726	19	349.98	10 VELCRO ABR. DISCS 150 G.240	10	349985	22
339.80	SANDING SPONGE GR.60/100	10	339801	19	349.99	10 VELCRO ABR. DISCS 150 G.ASS	10	349992	22
339.85	24 ABRASIVE SPONGES GR.60/100	1	339856	19	350.00	6 EMERY CLOTH DISCS 125 GR. 40	10	350004	20
339.90	2 AUTO SPONGES GR.100	10	339900	19	351.00	6 EMERY CLOTH DISCS 125 GR. 80	10	351001	20
340.00	15 PAPER SAND. DISCS 125 G. 50	10	340005	20	352.00	6 EMERY CLOTH DISCS 125 GR.120	10	352008	20
341.00	15 PAPER SAND. DISCS 125 G. 80	10	341002	20	353.00	6 EMERY CLOTH DISCS 125 ASS.	10	353005	20
342.00	15 PAPER SAND. DISCS 125 G.120	10	342009	20	354.00	10 VEL.ABR. SHEETS 93X185 40	5	354002	26
343.00	15 PAPER SANDING DISCS 125 ASS	10	343006	20	354.03	10 VEL.ABR. SHEETS 93X185 80	5	354033	26
344.00	5 PAPER SAND. DISCS 125 GR. 50	10	344003	20	354.06	10 VEL.ABR. SHEETS 93X185 120	5	354064	26
344.10	5 PAPER SAND. DISCS 125 GR. 80	10	344102	20	354.09	10 VEL.ABR. SHEETS 93X185 180	5	354095	26
344.20	5 PAPER SAND. DISCS 125 GR.120	10	344201	20	354.12	10 VEL.ABR. SHEETS 93X185 ASS	5	354125	26
344.30	5 PAPER SANDING DISCS 125 ASS.	10	344300	20	354.15	10 VEL.ABR. SHEETS 93X185 40	5	354156	26
347.00	6 FIBER BACKED DISCS 115 G. 36	10	347004	20	354.18	10 VEL.ABR. SHEETS 93X185 80	5	354187	26
347.10	6 FIBER BACKED DISCS 115 G. 60	10	347103	20	354.21	10 VEL.ABR. SHEETS 93X185 120	5	354217	26
347.20	6 FIBER BACKED DISCS 115 G.100	10	347202	20	354.24	10 VEL.ABR. SHEETS 93X185 180	5	354248	26
348.00	6 FIBER BACKED DISCS 180 G. 36	10	348001	20	354.27	10 VEL.ABR. SHEETS 93X185 ASS	5	354279	26
348.10	6 FIBER BACKED DISCS 180 G. 60	10	348100	20	354.30	10 ABRASIVE SHEETS 93X230 40	5	354309	26
348.20	6 FIBER BACKED DISCS 180 G.100	10	348209	20	354.33	10 ABRASIVE SHEETS 93X230 80	5	354330	26
348.30	5 VELCRO ABRASIVE SHEETS 40	10	348308	21	354.36	10 ABRASIVE SHEETS 93X230 120	5	354361	26
348.31	25 VELCRO ABRASIVE SHEETS 40	1	348315	21	354.39	10 ABRASIVE SHEETS 93X230 180	5	354392	26

# INDEX: REFERENCES, QUANTITIES AND BAR CODES

## Place number 8011017 before EAN code

ref.	description	☐	ean	page	ref.	description	☐	ean	page
354.42	10 ABRASIVE SHEETS 93X230 ASS	5	354422	26	357.30	10 SANDING SHEETS 115X280 ASS	10	357300	25
354.45	10 ABRASIVE SHEETS 93X230 40	5	354453	26	357.31	25 SANDING SHEETS 115X280 ASS	1	357317	25
354.48	10 ABRASIVE SHEETS 93X230 80	5	354484	26	357.35	3 SANDING BELTS 533X75 GR. 40	2	357355	29
354.51	10 ABRASIVE SHEETS 93X230 120	5	354514	26	357.36	3 SANDING BELTS 533X75 GR. 60	2	357362	29
354.54	10 ABRASIVE SHEETS 93X230 180	5	354545	26	357.37	3 SANDING BELTS 533X75 GR. 80	2	357379	29
354.57	10 ABRASIVE SHEETS 93X230 ASS	5	354576	26	357.38	3 SANDING BELTS 533X75 GR.100	2	357386	29
354.60	10 VEL.ABR. SHEETS 115X230 40	5	354606	26	357.39	3 SANDING BELTS 533X75 GR.150	2	357393	29
354.63	10 VEL.ABR. SHEETS 115X230 80	5	354637	26	357.40	3 SANDING BELTS 410X65 GR. 40	3	357409	29
354.66	10 VEL.ABR. SHEETS 115X230 120	5	354668	26	357.45	3 SANDING BELTS 410X65 GR. 60	3	357454	29
354.69	10 VEL.ABR. SHEETS 115X230 180	5	354699	26	357.50	3 SANDING BELTS 410X65 GR. 80	3	357508	29
354.72	10 VEL.ABR. SHEETS 115X230 ASS	5	354729	26	357.55	3 SANDING BELTS 410X65 GR.100	3	357553	29
354.75	10 ABRASIVE SHEETS 115X280 40	5	354750	26	357.57	3 SANDING BELTS 410X65 GR.150	3	357577	29
354.78	10 ABRASIVE SHEETS 115X280 80	5	354781	26	357.60	3 SANDING BELTS 510X75 GR. 40	2	357607	29
354.81	10 ABRASIVE SHEETS 115X280 120	5	354811	26	357.65	3 SANDING BELTS 510X75 GR. 60	2	357652	29
354.84	10 ABRASIVE SHEETS 115X280 180	5	354842	26	357.70	3 SANDING BELTS 510X75 GR. 80	2	357706	29
354.87	10 ABRASIVE SHEETS 115X280 ASS	5	354873	26	357.75	3 SANDING BELTS 510X75 GR.100	2	357751	29
355.10	3 SANDING BELTS 400X60 GR. 40	3	355108	28	357.77	3 SANDING BELTS 510X75 GR.150	2	357775	29
355.11	3 SANDING BELTS 400X60 GR. 60	3	355115	28	357.78	3 SANDING BELTS 457X75 GR. 40	2	357782	29
355.12	3 SANDING BELTS 400X60 GR. 80	3	355122	28	357.79	3 SANDING BELTS 457X75 GR. 60	2	357799	29
355.13	3 SANDING BELTS 400X60 GR.100	3	355139	28	357.80	3 SANDING BELTS 457X75 GR. 80	2	357805	29
355.14	3 SANDING BELTS 400X60 GR.150	3	355146	28	357.81	3 SANDING BELTS 457X75 GR.100	2	357812	29
355.15	3 SANDING BELTS 560X100 GR. 40	2	355153	28	357.82	3 SANDING BELTS 457X75 GR.150	2	357829	29
355.16	3 SANDING BELTS 560X100 GR. 60	2	355160	28	357.96	DRUM SANDER 45X30X6	10	357966	30
355.17	3 SANDING BELTS 560X100 GR. 80	2	355177	28	357.98	3 SANDING BELTS ASS. 357.96	10	357980	30
355.18	3 SANDING BELTS 560X100 GR.100	2	355184	28	358.00	FLAP SANDING DISC 115 NYLON 80	10	358000	31
355.19	3 SANDING BELTS 560X100 GR.150	2	355191	28	358.05	FLAP SANDING DISC 180 NYLON 80	10	358055	31
355.20	3 SANDING BELTS 610X100 GR. 40	2	355207	28	358.10	FLAP SANDING DISC 115 NYLON 40	10	358109	31
355.21	3 SANDING BELTS 610X100 GR. 60	2	355214	28	358.15	FLAP SANDING DISC 115 NYLON 80	10	358154	31
355.22	3 SANDING BELTS 610X100 GR. 80	2	355221	28	358.20	FLAP SANDING DISC 115 NYLON120	10	358208	31
355.23	3 SANDING BELTS 610X100 GR.100	2	355238	28	358.25	FLAP SANDING DISC 180 NYLON 40	10	358253	31
355.24	3 SANDING BELTS 610X100 GR.150	2	355245	28	358.30	FLAP SANDING DISC 180 NYLON 80	10	358307	31
355.25	3 SANDING BELTS 620X100 GR. 40	2	355252	28	358.35	FLAP SANDING DISC 180 NYLON120	10	358352	31
355.26	3 SANDING BELTS 620X100 GR. 60	2	355269	28	358.40	FLAP SANDING WHEEL 40X20MM 80	10	358406	30
355.27	3 SANDING BELTS 620X100 GR. 80	2	355276	28	358.50	FLAP SANDING WHEEL 50X20MM 80	10	358505	30
355.28	3 SANDING BELTS 620X100 GR.100	2	355283	28	358.60	FLAP SANDING WHEEL 60X40MM 80	10	358604	30
355.29	3 SANDING BELTS 620X100 GR.150	2	355290	28	358.80	FLAP SANDING WHEEL 80X30MM 80	10	358802	30
355.60	6 FINISHING PAPER SHEETS GR 60	10	355603	22	358.90	40 ASSORTED ROTARY FLAP SANDER	1	358901	30
355.62	6 FINISHING PAPER SHEETS GR100	10	355627	23	359.36	2 PRE-POLISHING PASTES	10	359366	17
355.64	6 FINISHING PAPER SHEETS GR150	10	355641	23	359.37	2 FINAL POLISHING PASTES	10	359373	17
355.66	6 FINISHING PAPER SHEETS ASS.	10	355665	23	359.38	2 ASSORTED POLISHING PASTES	10	359380	17
355.70	6 WET+DRY PAPER SHEETS GR 180	10	355702	23	359.40	FLAP WHEEL ABR.CLOTH 50X25	5	359403	18
355.72	6 WET+DRY PAPER SHEETS GR 320	10	355726	23	359.42	FLAP WHEEL ABR.CLOTH 75X45	5	359427	18
355.74	6 WET+DRY PAPER SHEETS GR 600	10	355740	23	359.44	FLAP WHEEL ABR.CLOTH 100X50	5	359441	18
355.76	6 WET+DRY PAPER SHEETS ASS.	10	355764	23	359.46	FLAP WHEEL ABR/EME.CLOTH 50X25	5	359465	18
355.80	6 EMERY CLOTH SHEETS GR 60	10	355801	24	359.48	FLAP WHEEL ABR/EME.CLOTH 75X45	5	359489	18
355.82	6 EMERY CLOTH SHEETS GR 120	10	355825	24	359.50	FLAP WHEEL ABR/EME.CLOTH100X50	5	359502	18
355.84	6 EMERY CLOTH SHEETS GR 240	10	355849	24	359.70	FLAP WHEEL ABR.CLOTH 150X25	5	359700	18
355.86	6 EMERY CLOTH SHEETS ASS.	10	355863	24	359.72	FLAP WHEEL ABR/EME.CLOTH150X25	5	359724	18
355.90	PAPER ROLL 5M GR. 50	2	355900	25	359.82	NYLON FIBER DISC 100X13MM	5	359823	18
355.92	PAPER ROLL 5M GR. 80	2	355924	25	359.86	NYLON FIBER DISC 115X22MM	5	359861	18
355.94	PAPER ROLL 5M GR.120	2	355948	25	363.00	ROUNDING OFF CUTTER 35MM	5	363004	39
355.96	VELCRO PAPER ROLL 3M GR. 50	2	355962	25	364.50	ROUNDING OFF CUTTER 25MM	5	364506	39
355.97	VELCRO PAPER ROLL 3M GR. 80	2	355979	25	368.00	SLOTING CUTTER 30X1,5MM	5	368009	39
355.98	VELCRO PAPER ROLL 3M GR.120	2	355986	25	369.00	SLOTING CUTTER 30X2,5MM	5	369006	39
356.00	10 SANDING SHEETS 93X230 50	10	356006	25	370.00	SLOTING SAW 45MM	5	370002	39
356.01	25 SANDING SHEETS 93X230 50	1	356013	25	373.00	ADJUSTABLE HAND SHAPER	1	373003	39
356.10	10 SANDING SHEETS 93X230 80	10	356105	25	374.03	ADJUSTABLE COUNTERSINK 3MM	10	374031	39
356.11	25 SANDING SHEETS 93X230 80	1	356112	25	374.04	ADJUSTABLE COUNTERSINK 4MM	10	374048	39
356.20	10 SANDING SHEETS 93X230 120	10	356204	25	374.05	ADJUSTABLE COUNTERSINK 5MM	10	374055	39
356.21	25 SANDING SHEETS 93X230 120	1	356211	25	374.06	ADJUSTABLE COUNTERSINK 6MM	10	374062	39
356.30	10 SANDING SHEETS 93X230 ASS	10	356303	25	375.00	COUNTERSINK 6MM	10	375007	40
356.31	25 SANDING SHEETS 93X230 ASS	1	356310	25	376.00	COUNTERSINK 12MM	10	376004	40
357.00	10 SANDING SHEETS 115X280 50	10	357003	25	377.00	COUNTERSINK 16MM	10	377001	40
357.01	25 SANDING SHEETS 115X280 50	1	357010	25	378.00	COUNTERSINK 19MM	10	378008	40
357.10	10 SANDING SHEETS 115X280 80	10	357102	25	379.00	COUNTERSINK 13MM	10	379005	40
357.11	25 SANDING SHEETS 115X280 80	1	357119	25	379.50	HINGE BORING BIT 20MM	10	379500	40
357.20	10 SANDING SHEETS 115X280 120	10	357201	25	380.00	HINGE BORING BIT 26MM	10	380001	40
357.21	25 SANDING SHEETS 115X280 120	1	357218	25	381.00	HINGE BORING BIT 30MM	10	381008	40

# INDEX: REFERENCES, QUANTITIES AND BAR CODES

## Place number 8011017 before EAN code

ref.	description	☐	ean	page	ref.	description	☐	ean	page
382.00	HINGE BORING BIT 35MM	10	382005	40	43.037	REDUCING COLLAR 43X37MM	1	430379	85
383.00	HINGE BORING BIT 38MM	10	383002	40	43.038	REDUCING COLLAR 43X38MM	1	430386	85
384.00	BORING BIT CARBIDE TIPPED 26MM	5	384009	40	43.384	REDUCING COLLAR 43X38,4MM	1	433844	85
384.10	BORING BIT CARBIDE TIPPED 30MM	5	384108	40	430.00	CYLINDRICAL ROTARY RASP	10	430003	43
384.20	BORING BIT CARBIDE TIPPED 35MM	5	384207	40	432.00	CONICAL ROTARY RASP	10	432007	43
384.50	FLAT WOOD DRILL BIT 6MM	10	384504	41	434.00	SPHERICAL ROTARY RASP	10	434001	43
385.00	FLAT WOOD DRILL BIT 8MM	10	385006	41	436.00	DOME ROTARY RASP	10	436005	43
386.00	FLAT WOOD DRILL BIT 10MM	10	386003	41	438.00	ROTARY COUNTERSINK	10	438009	43
387.00	FLAT WOOD DRILL BIT 12MM	10	387000	41	440.20	CONICAL ROTARY RASP HEX. SHANK	5	440200	43
388.00	FLAT WOOD DRILL BIT 14MM	10	388007	41	440.40	DOME ROTARY RASP HEX. SHANK	5	440408	43
389.00	FLAT WOOD DRILL BIT 16MM	10	389004	41	445.00	HSS WOOD/METAL DRILL SAW 6X85	10	445007	43
390.00	FLAT WOOD DRILL BIT 18MM	10	390000	41	445.20	CONICAL ROTARY FILE HEX. SHANK	5	445205	43
391.00	FLAT WOOD DRILL BIT 20MM	10	391007	41	445.30	DOME ROTARY FILE HEX. SHANK	5	445304	43
392.00	FLAT WOOD DRILL BIT 22MM	10	392004	41	446.00	SET 3 MINI ROTARY RASPS/FILES	10	446004	43
392.50	FLAT WOOD DRILL BIT 24MM	10	392509	41	447.00	SET 6 ROTARY RASPS/FILES	5	447001	43
393.00	FLAT WOOD DRILL BIT 25MM	10	393001	41	448.00	WOOD RASP 10/15MM	10	448008	44
393.20	FLAT WOOD DRILL BIT 26MM	10	393209	41	449.06	FLAT FILE/RASP 150MM - 6"	10	449067	44
393.40	FLAT WOOD DRILL BIT 28MM	10	393407	41	449.08	FLAT FILE/RASP 200MM - 8"	10	449081	44
393.60	FLAT WOOD DRILL BIT 30MM	10	393605	41	449.20	SET 6 ASSORTED FILES 100MM	5	449203	44
394.00	FLAT WOOD DRILL BIT 32MM	10	394008	41	449.40	2 ROUND CHAIN SAW FILES 5/32"	10	449401	44
394.20	FLAT WOOD DRILL BIT 35MM	10	394206	41	449.45	12 ROUND CHAIN SAW FILES 5/32"	2	449456	44
394.40	FLAT WOOD DRILL BIT 38MM	10	394404	41	449.50	2 ROUND CHAIN SAW FILES 3/16"	10	449500	44
394.70	FLAT WOOD DRILL BIT 15/45MM	2	394701	41	449.55	12 ROUND CHAIN SAW FILES 3/16"	2	449555	44
394.80	FLAT WOOD DRILL BIT 22/76MM	2	394800	41	449.60	2 ROUND CHAIN SAW FILES 7/32"	10	449609	44
394.84	EXTENSION SHANK 150MM	5	394848	41	449.65	12 ROUND CHAIN SAW FILES 7/32"	2	449654	44
394.86	EXTENSION SHANK 300MM	5	394862	41	451.00	HAND COUNTERSINK	10	451008	40
395.00	KNIFE-SCISSOR SHARPENER	10	395005	31	451.10	COUNTERSINK 10MM HEXAG.SHANK	5	451107	40
395.20	SHARPENING STONE	10	395203	31	452.00	MAGNETIC BIT HOLDER	10	452005	45
395.40	SHARPENING STONE BULK	10	395401	31	452.05	MAGNETIC BIT HOLDER QUICK REL.	5	452050	45
396.00	100 MOUNTED GRINDING POINTS	1	396002	32	452.10	MAGNETIC BIT HOLDER-DEPTH STOP	5	452104	45
397.00	45 MOUNTED GRINDING POINTS	1	397009	32	452.15	FLEXIBLE BIT HOLDER 190MM	5	452159	45
397.60	3 CHAIN SAWS SHARPENING POINTS	10	397603	32	452.20	BIT HOLDER SDS ATTACHMENT	5	452203	45
398.00	5 MOUNTED GRINDING POINTS 3MM	10	398006	32	452.30	ANGLE SCREWDRIVER	5	452302	45
399.00	5 MOUNTED GRINDING POINTS 6MM	10	399003	32	452.40	2 TORX BITS 10	10	452401	45
400.00	GRINDING WHEEL 75X10X10MM A96	10	400006	35	452.50	2 TORX BITS 15	10	452500	45
402.00	GRINDING WHEEL 75X10X13MM A96	10	402000	35	452.60	2 TORX BITS 20	10	452609	45
403.00	GRINDING WHEEL 75X10X13MM C49	10	403007	35	452.70	2 TORX BITS 25	10	452708	45
404.00	GRINDING WHEEL 100X12X13MM A96	10	404004	35	452.80	2 TORX BITS 30	10	452807	45
404.50	GRINDING WHEEL 125X15X16MM A96	10	404509	35	452.90	2 TORX BITS 40	10	452906	45
405.00	GRINDING WHEEL 150X20X16MM A96	10	405001	35	452.92	2 TIN TORX BITS 10	5	452920	45
406.00	METAL CUTTING DISC 125X2,5X13	10	406008	37	452.93	2 TIN TORX BITS 15	5	452937	45
406.95	METAL CUTTING DISC 115X1,0X22	10	406954	37	452.94	2 TIN TORX BITS 20	5	452944	45
407.00	METAL CUTTING DISC 115X1,6X22	10	407005	37	452.95	2 TIN TORX BITS 25	5	452951	45
407.05	METAL CUTTING DISC 115X1,6X22	10	407050	37	452.96	2 TIN TORX BITS 30	5	452968	45
408.00	STONE CUTTING DISC 125X2,5X13	10	408002	37	452.97	2 TIN TORX BITS 40	5	452975	45
409.00	STONE CUTTING DISC 115X1,6X22	10	409009	37	453.00	2 ALLEN KEY BITS 2MM	10	453002	46
409.05	STONE CUTTING DISC 115X1,6X22	10	409054	37	453.10	2 ALLEN KEY BITS 2,5MM	10	453101	46
413.00	METAL CUTTING DISC 115X3,2X22	10	413006	37	453.20	2 ALLEN KEY BITS 3MM	10	453200	46
413.05	METAL CUTTING DISC 115X3,2X22	10	413051	37	453.30	2 ALLEN KEY BITS 4MM	10	453309	46
413.50	STONE CUTTING DISC 115X3,2X22	10	413501	37	453.40	2 ALLEN KEY BITS 5MM	10	453408	46
413.55	STONE CUTTING DISC 115X3,2X22	10	413556	37	453.50	2 ALLEN KEY BITS 6MM	10	453507	46
414.00	METAL GRINDING DISC 115X6,4X22	10	414003	37	454.00	2 PHILLIPS BITS N.1	10	454009	46
414.05	METAL GRINDING DISC 115X6,4X22	10	414058	37	455.00	2 PHILLIPS BITS N.2	10	455006	46
414.50	STONE GRINDING DISC 115X6,4X22	10	414508	37	456.00	2 PHILLIPS BITS N.3	10	456003	46
414.55	STONE GRINDING DISC 115X6,4X22	10	414553	37	456.20	PHILLIPS BIT N.4	10	456201	46
419.60	UNIV.DIAMOND DISC TURBO 115MM	1	419602	38	456.50	2 PHILLIPS TIN BITS 1	5	456508	46
419.65	UNIV.DIAMOND DISC TURBO 230MM	1	419657	38	456.52	2 PHILLIPS TIN BITS 2	5	456522	46
419.70	SEGMENTED DIAMOND DISC 115MM	1	419701	38	456.54	2 PHILLIPS TIN BITS 3	5	456546	46
419.75	SEGMENTED DIAMOND DISC 230MM	1	419756	38	457.00	2 SLOT BITS 0,8X4MM	10	457000	46
419.80	DIAMOND DISC CONTIN.EDGE 115MM	1	419800	38	458.00	2 SLOT BITS 0,8X5MM	10	458007	46
419.85	DIAMOND DISC CONTIN.EDGE 230MM	1	419855	38	459.00	2 SLOT BITS 1,0X6MM	10	459004	46
419.90	WOOD CUTTING DISC 115M	5	419909	38	459.20	2 SLOT BITS 1,2X7,2MM	10	459202	46
419.95	WOOD CUTTING DISC 230M	1	419954	38	459.40	2 SLOT BITS 1,6X8MM	10	459400	46
420.00	CYLINDRICAL ROTARY FILE	10	420004	43	459.50	2 SLOT TIN BITS 0,8X4 MM	5	459509	46
422.00	CONICAL ROTARY FILE	10	422008	43	459.52	2 SLOT TIN BITS 0,8X5 MM	5	459523	46
424.00	CYLINDRICAL ROUNDED FILE	10	424002	43	459.54	2 SLOT TIN BITS 1,0X6 MM	5	459547	46
426.00	SPHERICAL ROTARY FILE	10	426006	43	459.90	2 POZIDRIV BITS N.0	10	459905	47
43.034	REDUCING COLLAR 43X34MM	1	430348	85	460.00	2 POZIDRIV BITS N.1	10	460000	47

# INDEX: REFERENCES, QUANTITIES AND BAR CODES

## Place number 8011017 before EAN code

ref.	description	☐	ean	page	ref.	description	☐	ean	page
460.10	2 POZIDRIV BITS N.2	10	460109	47	485.80	WHEEL BRUSH 75X13MM	10	485805	49
460.20	2 POZIDRIV BITS N.3	10	460208	47	486.00	WHEEL BRUSH 100X13MM	10	486000	49
460.30	POZIDRIV BIT N.4	10	460307	47	487.00	WHEEL BRUSH 120X16MM	10	487007	49
460.50	2 POZIDRIV TIN BITS 0	5	460505	47	488.00	WHEEL BRUSH 150X16MM	10	488004	49
460.52	2 POZIDRIV TIN BITS 1	5	460529	47	489.00	WHEEL BRUSH 200X20X20MM	1	489001	49
460.54	2 POZIDRIV TIN BITS 2	5	460543	47	489.50	WHEEL BRUSH 200X40X20MM	1	489506	49
460.56	2 POZIDRIV TIN BITS 3	5	460567	47	490.00	BRASS WHEEL BRUSH 75MM	10	490007	48
461.00	DOUBLE ENDED BIT 0,8X4 + PH1	10	461007	47	492.50	BRASS END BRUSH 25MM	10	492506	48
462.00	DOUBLE ENDED BIT 0,8X5 + PH2	10	462004	47	495.00	BRASS CUP BRUSH 50MM	10	495002	48
462.50	DOUBLE ENDED BIT 1,2X7,2 + PH3	10	462509	47	496.00	40 ASSORTED STEEL BRUSHES	1	496009	53
463.00	ASSORTED BIT SET 7 PCS	5	463001	47	496.50	30 ASSORTED NYLON BRUSHES	1	496504	53
465.02	HSS DRILL BIT 2MM HEX.SHANK	10	465029	87	496.65	KIT 4 ASSORTED STEEL BRUSHES	5	496658	56
465.03	HSS DRILL BIT 3MM HEX.SHANK	10	465036	87	496.70	KIT 3 ASSORTED BRASS BRUSHES	5	496702	56
465.04	HSS DRILL BIT 4MM HEX.SHANK	10	465043	87	496.75	KIT 3 ASS. NYLON BRUSHES G.80	5	496757	56
465.05	HSS DRILL BIT 5MM HEX.SHANK	10	465050	87	496.80	KIT 3 ASS. NYLON BRUSHES G.15	5	496801	56
466.00	CONICAL WHEEL BRUSH 90MM	10	466002	48	496.82	MINI STEEL HAND BRUSH	12	496825	55
466.01	20 CONICAL WHEEL BRUSHES 90MM	1	466019	48	496.84	MINI S/STEEL HAND BRUSH	12	496849	55
467.00	CONICAL WHEEL BRUSH 90MM	10	467009	48	496.85	MINI BRASS HAND BRUSH	12	496856	55
467.01	20 CONICAL WHEEL BRUSHES 90MM	1	467016	48	496.88	MINI NYLON HAND BRUSH	12	496887	55
468.00	CONICAL WHEEL BRUSH 120MM	10	468006	48	496.90	24 ASSORTED HAND BRUSHES	1	496900	53
468.01	20 CONICAL WHEEL BRUSHES 120MM	1	468013	48	496.93	NYLON HAND BRUSH	24	496931	54
468.20	CONICAL WHEEL BRUSH 150MM	5	468204	48	496.96	BRASS HAND BRUSH	24	496962	54
468.30	TWIS.CONIC.WHEEL BRUSH 100MM	5	468303	48	496.99	S/STEEL HAND BRUSH	24	496993	54
468.35	TWIS.CONIC.WHEEL BRUSH 120MM	5	468358	48	497.00	STEEL HAND BRUSH	24	497006	54
468.40	TWIS.CONIC.WHEEL BRUSH 150MM	5	468402	48	497.02	KIT 5 ASSORTED STEEL BRUSHES	3	497020	56
468.50	WHEEL BRUSH 40MM	10	468501	49	497.04	KIT 4 ASSORTED STEEL BRUSHES	10	497044	56
468.51	20 WHEEL BRUSHES 40MM	1	468518	49	497.05	NYLON WHEEL BRUSH 75MM GR. 80	5	497051	52
469.00	WHEEL BRUSH 50MM	10	469003	49	497.10	NYLON WHEEL BRUSH 75MM GR.150	5	497105	52
469.01	20 WHEEL BRUSHES 50MM	1	469010	49	497.15	NYLON WHEEL BRUSH 100MM GR. 80	5	497150	52
470.00	WHEEL BRUSH 75MM	10	470009	49	497.20	NYLON WHEEL BRUSH 100MM GR.150	5	497204	52
470.01	20 WHEEL BRUSHES 75MM	1	470016	49	497.25	NYLON CUP BRUSH 50MM GR. 80	5	497259	52
470.50	WHEEL BRUSH 75MM D.THICK	10	470504	49	497.30	NYLON CUP BRUSH 50MM GR.150	5	497303	52
475.00	WHEEL BRUSH 100MM	10	475004	49	497.35	NYLON CUP BRUSH 70MM GR. 80	5	497358	52
475.01	20 WHEEL BRUSHES 100MM	1	475011	49	497.40	NYLON CUP BRUSH 70MM GR.150	5	497402	52
475.50	WHEEL BRUSH 100MM D.THICK	10	475509	49	497.45	NYLON END BRUSH 25MM GR. 80	5	497457	52
475.65	TWISTED WHEEL BRUSH 75MM	5	475653	49	497.50	NYLON END BRUSH 25MM GR.150	5	497501	52
475.70	TWISTED WHEEL BRUSH 100MM	5	475707	49	497.55	NYLON FLAP BRUSH 100MM GR. 80	5	497556	52
476.00	3 ASSORTED MINI BRUSHES	10	476001	50	497.60	NYLON FLAP BRUSH 100MM GR.150	5	497600	52
477.00	END BRUSH 16MM	10	477008	50	50.020	DRILL STAND 43MM	1	500201	85
477.01	20 END BRUSHES 16MM	1	477015	50	50.030	DRILL STAND 60MM	1	500300	85
478.00	END BRUSH 25MM	10	478005	50	50.040	DRILL STAND 60MM	1	500409	85
478.01	20 END BRUSHES 25MM	1	478012	50	50.080	ANGLE GRINDER STAND 230MM	1	500805	84
478.20	END BRUSH 30MM MUSHROOM	10	478203	50	50.090	ANGLE GRINDER STAND 115MM	1	500904	84
478.40	END BRUSH 40MM MUSHROOM	10	478401	50	500.25	PROFESSIONAL SAFETY GLASSES	1	500256	58
478.80	SPIRAL BRUSH 16MM	10	478807	50	501.20	SAFETY GLASSES	1	501208	58
478.90	SPIRAL BRUSH 20MM	10	478906	50	501.60	PROFESSIONAL SAFETY GLASSES	1	501604	58
479.00	SPIRAL BRUSH 28MM	10	479002	50	502.00	5 PROTECTION MASKS	10	502007	58
479.01	20 SPIRAL BRUSHES 28MM	1	479019	50	502.50	50 PROTECTION MASKS	1	502502	58
479.10	SPIRAL BRUSH 38MM	10	479101	50	504.50	HALF MASK + A1 FILTER	1	504506	58
480.00	CUP BRUSH 50MM	10	480008	51	504.55	REPLACEMENT A1 FILTER 504.50	2	504551	58
480.01	20 CUP BRUSHES 50MM	1	480015	51	504.58	REPLACEMENT P3 FILTER 504.50	2	504582	58
485.00	CUP BRUSH 70MM	10	485003	51	504.70	HALF MASK + 2 A1 FILTERS	1	504704	59
485.01	20 CUP BRUSHES 70MM	1	485010	51	504.75	REPLACEMENT A1 FILTER 504.70	2	504759	59
485.20	CUP BRUSH 85MM	10	485201	51	504.78	REPLACEMENT P3 FILTER 504.70	2	504780	59
485.21	20 CUP BRUSHES 85MM	1	485218	51	505.00	EAR PROTECTOR	5	505008	59
485.30	CUP BRUSH 60MM M14	10	485300	51	505.20	EAR PROTECTOR	1	505206	59
485.31	20 CUP BRUSHES 60MM M14	1	485317	51	505.40	PROFESSIONAL EAR PROTECTOR	1	505404	59
485.40	CUP BRUSH 85MM M14	10	485409	51	505.80	3 PAIRS EAR PLUGS	10	505800	59
485.41	20 CUP BRUSHES 85MM M14	1	485416	51	505.83	5 PAIRS EAR PLUGS DOUBLE LAYER	10	505831	59
485.50	CUP BRUSH 100MM M14	5	485508	51	505.86	1 PAIR EAR PLUGS TRIPLE FLANGE	10	505862	59
485.51	10 CUP BRUSHES 100MM M14	1	485515	51	506.10	50 H.D. NITRILE GLOVES M	1	506104	60
485.60	CUP BRUSH 120MM M14	5	485607	51	506.11	50 H.D. NITRILE GLOVES L	1	506111	60
485.61	5 CUP BRUSHES 120MM M14	1	485614	51	506.12	50 H.D. NITRILE GLOVES XL	1	506128	60
485.65	CUP BRUSH 150MM M14	5	485652	51	506.19	100 NITRILE GLOVES S	1	506197	60
485.70	TWIS. CUP BRUSH 75MM M14	5	485706	51	506.20	100 NITRILE GLOVES M	1	506203	60
485.75	TWIS. CUP BRUSH 85MM M14	5	485751	51	506.21	100 NITRILE GLOVES L	1	506210	60
485.76	TWIS. CUP BRUSH 100MM M14	1	485768	51	506.22	100 NITRILE GLOVES XL	1	506227	60
485.77	TWIS. CUP BRUSH 120MM M14	1	485775	51	509.40	MIXING PADDLE 130X600MM	2	509402	61

# INDEX: REFERENCES, QUANTITIES AND BAR CODES

## Place number 8011017 before EAN code

ref.	description	☐	ean	page	ref.	description	☐	ean	page
510.00	MIXING PADDLE 60X350MM	10	510002	61	607.75	1000 STAPLES 14MM	10	607757	66
511.00	MIXING PADDLE 60X400MM	5	511009	61	611.10	TAPE-RULE MEASURE 3M	12	611105	67
512.00	MIXING PADDLE 80X400MM	5	512006	61	611.20	TAPE-RULE MEASURE 5M	6	611204	67
513.00	MIXING PADDLE 100X600MM	2	513003	61	611.25	12 TAPE-RULE MEASURES 5M	1	611259	67
514.00	MIXING PADDLE 120X600MM	2	514000	61	611.30	TAPE-RULE MEASURE 8M	4	611303	67
514.10	MIXING PADDLE 125X600MM D.HELI	2	514109	61	620.00	3 DEPTH STOP RINGS 6-8-10MM	10	620008	69
550.00	FLEXIBLE SHAFT 90CM	1	550008	78	620.10	DEPTH STOP RING 12MM	10	620107	69
555.08	CHUCK 8MM FOR FLEXIBLE SHAFT	1	555089	78	620.20	DEPTH STOP RING 14MM	10	620206	69
560.00	FLEXIBLE SHAFT 130CM PROFESS.	1	560007	78	624.00	WOODEN PLANE 36MM	1	624006	65
565.00	DUST CATCHER 4/10MM	10	565002	86	625.00	WOODEN PLANE 45MM	1	625003	65
566.00	METAL AUTOMATIC- SAFETY KNIFE	4	566009	62	626.00	WOODEN PLANE 48MM	1	626000	65
566.05	PROFESSIONAL KNIFE + 5 BLADES	4	566054	62	628.00	WOODEN REBATE PLANE 24MM	1	628004	65
566.11	CUTTER 5 BLADES - SELF LOADING	2	566115	62	629.00	WOODEN REBATE PLANE 27MM	1	629001	65
566.12	PROFESSIONAL CUTTER 25MM	12	566122	62	629.85	2 BLADES ELEC.PLANERS 75,5X5,5	5	629858	65
566.17	CUTTER 9MM/3 BLADES SELF-LOAD	12	566177	62	629.87	2 BLADES ELEC.PLANERS 80,5X5,5	5	629872	65
566.18	CUTTER 18MM/3 BLADES SELF-LOAD	12	566184	62	629.89	2 BLADES ELEC.PLANERS 82,0X5,5	5	629896	65
566.20	CUTTER 9MM METAL BODY	24	566207	62	630.03	WOOD DRILL BIT 3MM	10	630038	89
566.23	CUTTER 9MM ABS BODY	24	566238	62	630.04	WOOD DRILL BIT 4MM	10	630045	89
566.25	CUTTER 9MM METAL GUIDE	24	566252	62	630.05	WOOD DRILL BIT 5MM	10	630052	89
566.30	CUTTER 9MM ABS TRASP. BODY	24	566306	63	630.06	WOOD DRILL BIT 6MM	10	630069	89
566.40	CUTTER 18MM ABS TRASP. BODY	24	566405	63	630.07	WOOD DRILL BIT 7MM	10	630076	89
566.50	CUTTER 18MM METAL GUIDE	24	566504	63	630.08	WOOD DRILL BIT 8MM	10	630083	89
566.60	CUTTER 18MM METAL GUIDE	24	566603	63	630.09	WOOD DRILL BIT 9MM	10	630090	89
567.00	SCRAPER WITH ADJUSTABLE BLADE	24	567006	63	630.10	WOOD DRILL BIT 10MM	10	630106	89
568.00	5 MEDIUM HEAVY DUTY BLADES	12	568003	63	630.11	WOOD DRILL BIT 11MM	10	630113	89
568.10	5 LARGE HEAVY DUTY BLADES	12	568102	63	630.12	WOOD DRILL BIT 12MM	10	630120	89
568.20	5 HOOK BLADES	12	568201	63	630.13	WOOD DRILL BIT 13MM	10	630137	89
568.30	10 CUTTER BLADES 9MM	12	568300	63	630.14	WOOD DRILL BIT 14MM	10	630144	89
568.40	10 CUTTER BLADES 18MM	12	568409	63	649.00	CARPENTER PENCIL 180MM	144	009407	68
568.50	5 CUTTER BLADES 25MM	12	568508	63	649.06	6 CARPENTER PENCILS 180MM	5	649061	68
569.00	GLASS CUTTER	5	569000	63	650.00	DOWELLING JIG	1	650005	68
570.00	SET 5 WOOD CARVING TOOLS	2	570006	64	655.00	100 WOODEN DOWELS 6X30MM	10	655000	68
572.00	SET 6 WOOD CARVING TOOLS	2	572000	64	655.05	1000 WOODEN DOWELS 6X30MM	1	655055	68
575.00	FLAT CHISEL 6MM	5	575001	64	660.00	60 WOODEN DOWELS 8X35MM	10	660004	68
576.00	FLAT CHISEL 8MM	5	576008	64	660.05	1000 WOODEN DOWELS 8X35MM	1	660059	68
577.00	FLAT CHISEL 10MM	5	577005	64	662.00	60 WOODEN DOWELS 8X40MM	10	662008	68
578.00	FLAT CHISEL 12MM	5	578002	64	662.05	1000 WOODEN DOWELS 8X40MM	1	662053	68
579.00	FLAT CHISEL 14MM	5	579009	64	665.00	40 WOODEN DOWELS 10X40MM	10	665009	68
580.00	FLAT CHISEL 16MM	5	580005	64	665.05	1000 WOODEN DOWELS 10X40MM	1	665054	68
581.00	FLAT CHISEL 18MM	5	581002	64	666.00	30 WOODEN DOWELS 12X40MM	10	666006	68
582.00	FLAT CHISEL 20MM	5	582009	64	666.05	500 WOODEN DOWELS 12X40MM	1	666051	68
583.00	FLAT CHISEL 25MM	5	583006	64	668.00	100 WOODEN DOWELS 6X1000MM	1	668000	68
584.00	FLAT CHISEL 30MM	5	584003	64	668.10	100 WOODEN DOWELS 8X1000MM	1	668109	68
585.00	FLAT CHISEL 32MM	5	585000	64	668.20	100 WOODEN DOWELS 10X1000MM	1	668208	68
586.00	FLAT CHISEL 38MM	5	586007	64	668.30	50 WOODEN DOWELS 12X1000MM	1	668307	68
590.00	WOOD GIMLET 2MM	10	590004	64	668.40	40 WOODEN DOWELS 14X1000MM	1	668406	68
591.00	WOOD GIMLET 3MM	10	591001	64	668.50	40 WOODEN DOWELS 16X1000MM	1	668505	68
592.00	WOOD GIMLET 4MM	10	592008	64	669.00	50 JOINTING BISCUITS 0	10	669007	69
593.00	WOOD GIMLET 5MM	10	593005	64	669.05	1000 JOINTING BISCUITS 0	1	669052	69
594.00	WOOD GIMLET 6MM	10	594002	64	669.10	50 JOINTING BISCUITS 10	10	669106	69
597.00	WOOD GIMLETS 2-3-4MM	10	597003	64	669.15	1000 JOINTING BISCUITS 10	1	669151	69
598.50	MARKING PEN CARBIDE TIPPED	5	598505	79	669.20	50 JOINTING BISCUITS 20	10	669205	69
599.00	GLUE GUN 20W-7MM	1	599007	79	669.25	1000 JOINTING BISCUITS 20	1	669250	69
599.20	GLUE GUN 40W-11MM	1	599205	79	670.00	4 CENTER POINTS 6MM	10	670003	69
60.043	REDUCING COLLAR 60X43MM	1	600437	85	675.00	4 CENTER POINTS 8MM	10	675008	69
60.046	REDUCING COLLAR 60X46MM	1	600468	85	680.00	4 CENTER POINTS 10MM	10	680002	69
60.050	REDUCING COLLAR 60X50MM	1	600505	85	680.10	4 CENTER POINTS 12MM	10	680101	69
60.053	REDUCING COLLAR 60X53MM	1	600536	85	680.20	2 CENTER POINTS 14MM	10	680200	69
60.054	REDUCING COLLAR 60X54MM	1	600543	85	681.00	DOWELLING KIT 6MM	5	681009	69
60.056	REDUCING COLLAR 60X56MM	1	600567	85	682.00	DOWELLING KIT 8MM	5	682006	69
600.00	12 GLUE STICKS 7X100MM	10	600000	79	683.00	DOWELLING KIT 10MM	5	683003	69
600.20	12 GLUE STICKS 11X100MM	10	600208	79	684.00	3 HSS JIGSAW BLADES B&D	10	684000	70
601.00	TACKER	1	601007	66	685.00	3 HSS JIGSAW BLADES B&D	10	685007	70
604.00	ADJUSTABLE TACKER METAL BODY	1	604008	66	686.00	3 HSS JIGSAW BLADES B&D	10	686004	70
607.35	1000 STAPLES 6MM	10	607351	66	686.50	3 HSS JIGSAW BLADES B&D 80MM	10	686509	70
607.45	1000 STAPLES 8MM	10	607450	66	687.00	3 CV JIGSAW BLADES B&D	10	687001	70
607.55	1000 STAPLES 10MM	10	607559	66	688.00	3 CV JIGSAW BLADES B&D	10	688008	70
607.65	1000 STAPLES 12MM	10	607658	66	689.00	3 CV JIGSAW BLADES B&D	10	689005	70

# INDEX: REFERENCES, QUANTITIES AND BAR CODES

## Place number 8011017 before EAN code

ref.	description	☐	ean	page	ref.	description	☐	ean	page
689.10	3 CV JIGSAW GROUN. BLADES B&D	10	689104	70	764.00	KEYLESS CHUCK 13MM FEMALE THR.	1	764009	76
689.20	3 CV JIGSAW GROUN. BLADES B&D	10	689203	70	766.00	KEYLESS CHUCK 10MM FEMALE THR.	1	766003	76
689.50	3 CV JIGSAW BLADES B&D 100MM	10	689500	70	768.00	KEYLESS CHUCK 13MM FEMALE THR.	1	768007	76
694.00	3 HSS JIGSAW BLADES BOSCH	10	694009	71	773.00	KEYLESS CHUCK 10MM MALE THR.	1	773001	76
695.00	3 HSS JIGSAW BLADES BOSCH	10	695006	71	774.00	KEYLESS CHUCK 10MM FEMALE THR.	1	774008	76
696.00	3 HSS JIGSAW BLADES BOSCH	10	696003	71	774.50	KEYLESS CHUCK 13MM FEMALE THR.	1	774503	76
696.50	3 HSS JIGSAW BLADES BOSCH 80MM	10	696508	71	775.00	KEYLESS CHUCK 10MM FEMALE THR.	1	775005	76
697.00	3 CV JIGSAW BLADES BOSCH	10	697000	71	775.50	KEYLESS CHUCK 13MM FEMALE THR.	1	775500	76
698.00	3 CV JIGSAW BLADES BOSCH	10	698007	71	775.51	KEYLESS CHUCK 13MM-SDS+	1	775517	76
699.00	3 CV JIGSAW BLADES BOSCH	10	699004	71	775.60	KEYLESS CHUCK 13MM FEMALE THR.	1	775609	76
699.10	3 CV JIGSAW GROUN.BLADES BOSCH	10	699103	71	775.61	KEYLESS CHUCK 13MM-SDS+	1	775616	76
699.20	3 CV JIGSAW GROUN.BLADES BOSCH	10	699202	71	780.00	CHUCK WITH KEY 10MM MALE THR	1	780009	77
699.50	3 CV JIGSAW BLADES BOSCH 100MM	10	699509	71	781.00	CHUCK WITH KEY 13MM MALE THR	1	781006	77
699.60	2 CV JIGSAW BLADES BOSCH 220MM	10	087399	71	783.00	CHUCK WITH KEY 10MM FEMALE THR	1	783000	77
704.00	3 HSS JIGSAW BLADES BOSCH	10	704005	72	784.00	CHUCK WITH KEY 13MM FEMALE THR	1	784007	77
705.00	3 HSS JIGSAW BLADES BOSCH	10	705002	72	786.00	CHUCK WITH KEY 10MM FEMALE THR	1	786001	77
706.00	3 HSS JIGSAW BLADES BOSCH	10	706009	72	787.00	CHUCK WITH KEY 13MM FEMALE THR	1	787008	77
707.00	3 CV JIGSAW BLADES BOSCH	10	707006	72	787.01	CHUCK WITH KEY 13MM-SDS+	1	787015	77
708.00	3 CV JIGSAW BLADES BOSCH	10	708003	72	788.00	CHUCK WITH KEY 10 HEXAG. SHANK	1	788005	77
714.00	3 HSS JIGSAW BLADES MAKITA	10	714004	72	788.50	CHUCK 0,5-6,5MM - HEX. SHANK	5	788500	77
715.00	3 HSS JIGSAW BLADES MAKITA	10	715001	72	789.00	CHUCK ADAPTOR SDS+ 1/2X20	5	789002	78
716.00	3 HSS JIGSAW BLADES MAKITA	10	716008	72	789.10	M6 LEFT HAND SCREW FOR CHUCKS	1	789101	78
717.00	3 CV JIGSAW BLADES MAKITA	10	717005	72	789.50	CHUCK ADAPTOR M3/8-M1/2	1	789507	78
718.00	3 CV JIGSAW BLADES MAKITA	10	718002	72	789.60	CHUCK ADAPTOR M3/8-M3/8	1	789606	78
720.00	3 CV JIGSAW BLADES B&D	10	720005	70	789.70	CHUCK ADAPTOR M1/2-F3/8	1	789705	78
720.90	10 ASSORTED B&D JIG SAW BLADES	3	720906	70	790.00	DRILL CHUCK KEY 10MM B&D	10	790008	78
721.00	3 CV JIGSAW BLADES BOSCH	10	721002	71	791.00	DRILL CHUCK KEY 13MM B&D	10	791005	78
721.90	10 ASS. BOSCH JIG SAW BLADES	3	721903	71	792.00	UNIVERSAL DRILL CHUCK KEY 13MM	10	792002	78
722.00	3 CV JIGSAW BLADES MAKITA	10	722009	72	793.00	UNIVERSAL DRILL CHUCK KEY 16MM	5	793009	78
724.00	TUNGSTEN CARBIDE BLADE B&D	5	724003	70	794.00	UNIVERSAL DRILL CHUCK KEY	5	794006	78
725.00	TUNGSTEN CARBIDE BLADE BOSCH	5	725000	71	800.00	HSS ENLARGING CUTTER 3/14MM	1	800004	12
728.00	GLASS DRILL BIT 3MM	5	728001	86	805.00	HSS ENLARGING CUTTER 6/20MM	1	805009	12
728.10	GLASS DRILL BIT 4MM	5	728100	86	810.00	HSS ENLARGING CUTTER 8/30MM	1	810003	12
728.20	GLASS DRILL BIT 5MM	5	728209	86	820.00	HSS ENLARGING CUTTER 20/40MM	1	820002	12
728.30	GLASS DRILL BIT 6MM	5	728308	86	825.00	HSS ENLARGING CUTTER 20/50MM	1	825007	12
728.40	GLASS DRILL BIT 8MM	5	728407	86	825.50	HSS STEP DRILL BIT 4/12MM	1	825502	12
728.50	GLASS DRILL BIT 10MM	5	728506	86	826.00	HSS STEP DRILL BIT 4/20MM	1	826004	12
728.60	GLASS DRILL BIT 12MM	5	728605	86	828.00	HSS STEP DRILL BIT 4/30MM	1	828008	12
730.00	HOLE SAW 25/62MM 25MM	10	730004	73	829.00	HSS STEP DRILL BIT 3,5/40MM	1	829005	12
732.00	HOLE SAW 25/62MM 50MM	10	732008	73	835.00	HSS ENLARGING CUTTER 0/25MM	5	835006	13
735.00	HOLE SAW 60/95MM 40MM	5	735009	73	835.50	HSS ENLARGING CUTTER 6/32MM	1	835501	13
740.00	C.V.CIRC.SAW BLADE 125X20 T.24	5	740003	75	835.60	HSS ENLARGING CUTTER 6/45MM	1	835600	13
745.00	C.V.CIRC.SAW BLADE 125X20 T.80	5	745008	75	840.00	HSS COUNTERSINK 12MM	5	840000	13
750.00	C.V.CIRC.SAW BLADE 150X20 T.24	5	750002	75	845.00	HSS COUNTERSINK 16MM	5	845005	13
755.00	C.V.CIRC.SAW BLADE 150X20 T.80	5	755007	75	850.00	HSS COUNTERSINK 20MM	5	850009	13
756.02	H.M.CIRC.SAW BLADE 125X20 T.18	1	756028	75	880.00	WET GRINDING WHEEL 100X20X16	1	880006	35
756.10	H.M.CIRC.SAW BLADE 150X20 T.20	1	756103	75	882.00	GRINDING WHEEL FOR ART.880.00	1	882000	35
756.12	H.M.CIRC.SAW BLADE 150X30 T.34	1	756127	75	890.00	DRILL POWERED WATER PUMP	5	890005	80
756.14	H.M.CIRC.SAW BLADE 160X20 T.24	1	756141	75	921.00	6MM HAND DRILL	5	921006	80
756.16	H.M.CIRC.SAW BLADE 160X20 T.36	1	756165	75	928.00	13MM HAND DRILL	1	928005	80
756.18	H.M.CIRC.SAW BLADE 170X30 T.18	1	756189	75	930.00	CHUCK 6MM FOR HAND DRILL	1	930008	80
756.20	H.M.CIRC.SAW BLADE 170X30 T.36	1	756202	75	936.00	CHUCK 13MM FOR HAND DRILL	1	936000	80
756.24	H.M.CIRC.SAW BLADE 180X30 T.36	1	756240	75	946.00	8 HEXAGONAL KEY WRENCHES	10	946009	80
756.30	H.M.CIRC.SAW BLADE 190X30 T.42	1	756301	75	946.50	10 HEXAGONAL KEY WRENCHES	10	946504	80
756.32	H.M.CIRC.SAW BLADE 200X30 T.42	1	756325	75	948.00	CARPENTERS CLAMP 150MM	6	948003	81
756.38	H.M.CIRC.SAW BLADE 210X30 T.30	1	756387	75	948.10	CARPENTERS CLAMP 200MM	6	948102	81
756.40	H.M.CIRC.SAW BLADE 210X30 T.42	1	756400	75	948.20	CARPENTERS CLAMP 250MM	6	948201	81
756.42	H.M.CIRC.SAW BLADE 230X30 T.20	1	756424	75	948.30	CARPENTERS CLAMP 300MM	6	948300	81
756.44	H.M.CIRC.SAW BLADE 230X30 T.34	1	756448	75	948.40	CARPENTERS CLAMP 400MM	4	948409	81
756.48	H.M.CIRC.SAW BLADE 250X30 T.24	1	756486	75	948.50	CARPENTERS CLAMP 500MM	4	948508	81
756.50	H.M.CIRC.SAW BLADE 250X30 T.48	1	756509	75	948.60	CARPENTERS CLAMP 600MM	4	948607	81
756.52	H.M.CIRC.SAW BLADE 250X30 T.60	1	756523	75	948.65	CARPENTERS CLAMP 700MM	2	948652	81
756.56	H.M.CIRC.SAW BLADE 300X30 T.72	1	756561	75	948.70	CARPENTERS CLAMP 800MM	2	948706	81
756.58	H.M.CIRC.SAW BLADE 300X30 T.96	1	756585	75	948.80	CARPENTERS CLAMP 1000MM	2	948805	81
756.60	H.M.CIRC.SAW BLADE 350X30 T.84	1	756608	75	948.82	CARPENTERS CLAMP 1200MM	2	948829	81
756.62	H.M.CIRC.SAW BLADE 350X30 T108	1	756622	75	948.84	CARPENTERS CLAMP 1500MM	2	948843	81
760.00	KEYLESS CHUCK 10MM MALE THR.	1	760001	76	948.93	ONE HAND CLAMP 150MM	4	948935	81
762.00	KEYLESS CHUCK 10MM FEMALE THR.	1	762005	76	948.95	ONE HAND CLAMP 300MM	4	948959	81



# INDEX: REFERENCES, QUANTITIES AND BAR CODES

## Place number 8011017 before EAN code

ref.	description	☐	ean	page	ref.	description	☐	ean	page
948.97	ONE HAND CLAMP 450MM	4	948973	81	MA/ME	GRINDING POINTS	10		33
949.00	ALUMINIUM C CLAMP 80X65MM	1	949000	81	MF/MN	GRINDING POINTS	11		34
949.10	ALUMINIUM C CLAMP 105X75MM	1	949109	81	RC.01	PAPER ROLL 120X50 YDS GR 40	1	085159	24
949.20	ALUMINIUM C CLAMP 160X75MM	1	949208	81	RC.03	PAPER ROLL 120X50 YDS GR 60	1	085166	24
949.50	CLAMP 50MM	5	949505	82	RC.04	PAPER ROLL 120X50 YDS GR 80	1	085173	24
949.60	CLAMP 75MM	5	949604	82	RC.05	PAPER ROLL 120X50 YDS GR 100	1	085180	24
949.70	CLAMP 100MM	5	949703	82	RC.06	PAPER ROLL 120X50 YDS GR 120	1	085197	24
951.00	CLAMP 25MM	10	951003	82	RC.07	PAPER ROLL 120X50 YDS GR 150	1	085203	24
952.00	CLAMP 50MM	10	952000	82	RC.08	PAPER ROLL 120X50 YDS GR 180	1	085210	24
953.00	CLAMP 75MM	10	953007	82	RC.09	PAPER ROLL 120X50 YDS GR 240	1	085227	24
954.00	QUICK PRESS VICE 65MM	1	954004	82	RG/RG	FLAP SANDING WHEELS	10		30
955.00	MOBILE CLAMP 90°	1	955001	82	T.01	EMERY CLOTH SHEETS 23X28 GR 30	50	085869	24
956.00	CORNER CLAMP	5	956008	82	T.03	EMERY CLOTH SHEETS 23X28 GR 40	50	085876	24
957.00	QUICK ADJUSTING BAND CLAMP 4M	1	957005	83	T.04	EMERY CLOTH SHEETS 23X28 GR 60	50	085883	24
957.50	RATCHET CLAMP 50MM	5	957500	83	T.05	EMERY CLOTH SHEETS 23X28 GR 80	50	085890	24
958.00	4 MINI SPRING CLAMPS 18MM	10	958002	83	T.06	EMERY CLOTH SHEETS 23X28 GR100	50	085906	24
958.05	SPRING CLAMP 30MM	10	958057	83	T.07	EMERY CLOTH SHEETS 23X28 GR120	50	085913	24
958.07	SPRING CLAMP 40MM	10	958071	83	T.08	EMERY CLOTH SHEETS 23X28 GR150	50	085920	24
958.10	SPRING CLAMP 60MM	10	958101	83	T.09	EMERY CLOTH SHEETS 23X28 GR180	50	085937	24
958.14	SPRING CLAMP 70MM	10	958149	83	T.10	EMERY CLOTH SHEETS 23X28 GR220	50	085944	24
960.00	ROTARY DRILL CLAMP 43MM	1	960005	84	T.11	EMERY CLOTH SHEETS 23X28 GR240	50	085951	24
970.00	DRILL AND MILL ATTACHMENT 43MM	1	970004	84	T.12	EMERY CLOTH SHEETS 23X28 GR320	50	085968	24
972.00	MOBILE DRILL STAND 43MM 0/45°	1	972008	84	T.13	EMERY CLOTH SHEETS 23X28 GR400	50	085975	24
A96/C49	GRINDING WHEELS	1		36	WSC.001	WET+DRY PAPER SHEETS GR 100	100	085982	23
C48/C48	DRESSING STONES	2		35	WSC.002	WET+DRY PAPER SHEETS GR 120	100	085999	23
DG/DG	GRINDING STONES	1		35	WSC.003	WET+DRY PAPER SHEETS GR 150	100	086002	23
ESPO.S1	DISPLAYER FOR BRUSHES 134 PCS	1	087450	57	WSC.004	WET+DRY PAPER SHEETS GR 180	100	086019	23
ESPO.S2	DISPLAYER FOR BRUSHES 94 PCS	1	087702	57	WSC.005	WET+DRY PAPER SHEETS GR 220	100	086026	23
FC.01	FINISHING PAPER SHEETS GR 40	100	083346	23	WSC.006	WET+DRY PAPER SHEETS GR 240	100	086033	23
FC.03	FINISHING PAPER SHEETS GR 60	100	083353	23	WSC.007	WET+DRY PAPER SHEETS GR 280	100	086040	23
FC.04	FINISHING PAPER SHEETS GR 80	100	083360	23	WSC.008	WET+DRY PAPER SHEETS GR 320	100	086057	23
FC.05	FINISHING PAPER SHEETS GR 100	100	083377	23	WSC.009	WET+DRY PAPER SHEETS GR 360	100	086064	23
FC.06	FINISHING PAPER SHEETS GR 120	100	083384	23	WSC.010	WET+DRY PAPER SHEETS GR 400	100	086071	23
FC.07	FINISHING PAPER SHEETS GR 150	100	083391	23	WSC.011	WET+DRY PAPER SHEETS GR 500	100	086088	23
FC.08	FINISHING PAPER SHEETS GR 180	100	083407	23	WSC.012	WET+DRY PAPER SHEETS GR 600	100	086095	23
LQU/LTR	GRINDING FILES	10		35					
M.1010	2 STEEL BALL CUTTERS 1,4	5	090009	92	M.1770	HSS ROUTER BIT V GROOVES 6,4MM	2	090351	93
M.1020	2 STEEL BALL CUTTERS 2,3	5	090016	92	M.1905	DIAMOND BALL BIT 1,0MM	5	090245	94
M.1030	STEEL BALL CUTTER 4,0	5	090092	92	M.1910	DIAMOND BALL BIT 1,4MM	5	090252	94
M.1050	STEEL BALL CUTTER 6,0	5	090108	92	M.1915	DIAMOND BALL BIT 1,8MM	5	090269	94
M.1065	STEEL OVAL CUTTER 7,8	5	092928	92	M.1925	DIAMOND CYLINDRICAL BIT 1,5MM	5	090276	94
M.1070	2 STEEL CYLINDR. CUTTERS 1,4	5	090023	92	M.1935	DIAMOND CYLINDRICAL BIT 3,2MM	5	090283	94
M.1080	2 STEEL CYLINDR. CUTTERS 2,3	5	090030	92	M.1950	DIAMOND FLAME BIT 1,6MM	5	090290	94
M.1100	STEEL CYLINDRICAL CUTTER 6,0	5	090115	92	M.1970	DIAMOND POINT BIT 2,8MM	5	090306	94
M.1105	STEEL CYLINDRICAL CUTTER 7,8	5	092935	92	M.1980	DIAMOND DISC BIT 5,0MM	5	090313	94
M.1120	2 STEEL REV. TAPER CUTTERS 1,4	5	090047	92	M.2010	2 RUBY GRINDING STONES 3X8MM	5	090368	95
M.1130	2 STEEL REV. TAPER CUTTERS 2,3	5	090054	92	M.2025	2 RUBY GRINDING STONES 5X10MM	5	090375	95
M.1140	STEEL REVER.TAPER CUTTERS 4,0	5	090122	92	M.2040	2 RUBY GRINDING STONES 8X10MM	5	090382	95
M.1170	2 STEEL FLAME CUTTERS 2,3	5	090061	92	M.2055	2 RUBY GRINDING STONES 10X12MM	5	090399	95
M.1190	STEEL FLAME CUTTER 4,0	5	090139	92	M.2070	2 RUBY GRINDING STONES 12X15MM	5	090405	95
M.1240	STEEL CONE CUTTER 6,0	5	090146	92	M.2085	2 RUBY GRINDING STONES 3X8MM	5	090412	95
M.1270	2 STEEL COUNTERS. CUTTERS 2,3	5	090078	92	M.2100	2 RUBY GRINDING STONES 5X10MM	5	090429	95
M.1310	STEEL POINT CUTTER 6,0	5	090153	92	M.2115	2 RUBY GRINDING STONES 8X12MM	5	090436	95
M.1340	2 STEEL WHEEL CUTTERS 2,3	5	090085	92	M.2130	2 RUBY GRINDING STONES 6X10MM	5	090443	95
M.1370	STEEL WHEEL CUTTER 6,0	5	090160	92	M.2145	2 RUBY GRINDING STONES 10X20MM	5	090450	95
M.1375	STEEL WHEEL CUTTER 9,5	5	092942	92	M.2160	2 RUBY GRINDING STONES 6MM	5	090467	95
M.1510	TUNGSTEN CARBIDE CUTTER 1,8MM	5	090177	93	M.2175	2 RUBY GRINDING STONES 10MM	5	090474	95
M.1520	TUNGSTEN CARBIDE CUTTER 3MM	5	090184	93	M.2190	2 RUBY GRINDING STONES 6X12MM	5	090481	95
M.1540	TUNGSTEN CARBIDE CUTTER 1,8MM	5	090191	93	M.2205	2 RUBY GRINDING STONES 8X15MM	5	090498	95
M.1550	TUNGSTEN CARBIDE CUTTER 3MM	5	090207	93	M.2220	2 RUBY GRINDING STONES 10X20MM	5	090504	95
M.1560	TUNGSTEN CARBIDE CUTTER 1,8MM	5	090214	93	M.2235	2 RUBY GRINDING STONES 8X6MM	5	090511	95
M.1570	TUNGSTEN CARBIDE CUTTER 3MM	5	090221	93	M.2410	2 SILICON CARBIDE STONES 3X8MM	5	090528	96
M.1580	TUNGSTEN CARBIDE CUTTER 3MM	5	090238	93	M.2420	2 SILICON CARBIDE STONES 5X10	5	090535	96
M.1710	HSS ROUNDING OFF CUTTER 3MM	2	090320	93	M.2435	2 SILICON CARBIDE STONES 4MM	5	090542	96
M.1720	HSS COVING CUTTER 4MM	2	090337	93	M.2450	2 SILICON CARBIDE STONES 8X6MM	5	090559	96
M.1750	HSS FLUTE BIT GROOVES 3MM	2	090344	93	M.2465	2 SILICON CARBIDE STONES 6X10	5	090566	96

# INDEX: REFERENCES, QUANTITIES AND BAR CODES

## Place number 8011017 before EAN code

ref.	description	☐	ean	page	ref.	description	☐	ean	page
M.2480	2 SILICON CARBIDE STONES 5X10	5	090573	96	M.5130	2 METAL ROUGHING DISCS 32X2,2	5	091143	103
M.2510	2 RUBY GRINDING STONES 22MM	5	090580	96	M.5405	MINI STEEL SAW BLADE 13MM	5	091150	104
M.2520	2 SILICON CARBIDE STONES 22MM	5	090597	96	M.5410	MINI STEEL SAW BLADE 19MM	5	091167	104
M.2610	2 RUBY GRINDING STONES 22MM	5	090603	96	M.5415	MINI STEEL SAW BLADE 25MM	5	091174	104
M.2620	2 SILICON CARBIDE STONES 22MM	5	090610	96	M.5710	DIAMOND DISC 22MM	5	091181	104
M.2630	2 WHITE GRINDING STONES 22MM	5	090627	96	M.5715	DIAMOND DISC 30MM	5	093314	104
M.2640	2 BROWN GRINDING STONES 22MM	5	090634	96	M.5720	DIAMOND DISC 40MM	5	093321	104
M.2710	2 CHAIN SHARP. WHEELS 4,0X19MM	5	090641	97	M.5750	SEGMENTED DIAMOND DISC 22MM	5	093338	104
M.2715	2 CHAIN SHARP. WHEELS 4,8X19MM	5	090658	97	M.5905	SPIRAL WOOD CUTTING BIT 3,2MM	5	093345	104
M.2720	2 CHAIN SHARP. WHEELS 5,6X21MM	5	090665	97	M.5910	SPIRAL DRYWALL CUTTING BIT 3,2	5	093352	104
M.2910	DRESSING STONE DOUBLE GRAIN	5	090672	97	M.5915	SPIRAL TILE CUTTING BIT 3,2MM	5	093369	104
M.3020	FLAP SANDING WHEEL 20X05MM 80	5	090689	98	M.6005	2 HSS DRILL BITS 0,5MM	5	091198	105
M.3030	FLAP SANDING WHEEL 30X10MM 80	5	090696	98	M.6006	2 HSS DRILL BITS 0,6MM	5	091204	105
M.3210	BACKING PAD + 6 SANDING DISCS	5	090702	98	M.6008	2 HSS DRILL BITS 0,8MM	5	091211	105
M.3220	10 ADHESIVE DISCS 20MM GR.100	5	090719	98	M.6010	2 HSS DRILL BITS 1,0MM	5	091228	105
M.3230	10 ADHESIVE DISCS 20MM GR.220	5	090726	98	M.6012	2 HSS DRILL BITS 1,2MM	5	091235	105
M.3610	DRUM SANDER 13X13MM	5	090733	98	M.6015	2 HSS DRILL BITS 1,5MM	5	091242	105
M.3620	12 SANDING BELTS 13MM GR. 60	5	090740	98	M.6020	2 HSS DRILL BITS 2,0MM	5	091259	105
M.3630	12 SANDING BELTS 13MM GR.120	5	090757	98	M.6024	2 HSS DRILL BITS 2,4MM	5	091266	105
M.3640	DRUM SANDER 9,5X13MM	5	092959	99	M.6030	2 HSS DRILL BITS 3,0MM	5	091273	105
M.3650	12 SANDING BELTS 9,5MM GR. 60	5	092966	99	M.6100	20 HSS DRILL BITS 0,3/1,6MM	2	091396	105
M.3660	12 SANDING BELTS 9,5MM GR.120	5	092973	99	M.6206	REINF. HSS DRILL BIT 0,6MM	5	091280	105
M.3670	DRUM SANDER 6,3X13MM	5	092980	99	M.6208	REINF. HSS DRILL BIT 0,8MM	5	091297	105
M.3680	12 SANDING BELTS 6,3MM GR. 60	5	092997	99	M.6210	REINF. HSS DRILL BIT 1,0MM	5	091303	105
M.3690	12 SANDING BELTS 6,3MM GR.120	5	093000	99	M.6212	REINF. HSS DRILL BIT 1,2MM	5	091310	105
M.4005	STEEL END WIRE BRUSH 5MM	5	090764	100	M.6215	REINF. HSS DRILL BIT 1,5MM	5	091327	105
M.4010	STEEL CUP BRUSH 12MM	5	090771	100	M.6220	REINF. HSS DRILL BIT 2,0MM	5	091334	105
M.4015	STEEL WHEEL BRUSH 21MM	5	090788	100	M.8010	5 COLLETS + COLLET NUT	2	093017	106
M.4020	3 ASSORTED STEEL BRUSHES	5	090795	100	M.8020	4 COLLETS + COLLET NUT DREMEL	2	093024	106
M.4055	BRASS END WIRE BRUSH 5MM	5	090801	100	M.8100	MANDREL	5	091358	106
M.4060	BRASS CUP BRUSH 12MM	5	090818	100	M.8110	REINFORCED MANDREL	5	091365	106
M.4065	BRASS WHEEL BRUSH 21MM	5	090825	100	M.8120	PYRAMIDAL MANDREL	5	091372	106
M.4070	3 ASSORTED BRASS BRUSHES	5	090832	100	M.8210	KIT 10 ENGRAVING ACCESSORIES	2	093031	107
M.4105	BLACK BRISTLE END BRUSH 5MM	5	090849	100	M.8230	KIT 10 GRINDING ACCESSORIES	2	093048	107
M.4110	BLACK BRISTLE CUP BRUSH 12MM	5	090856	100	M.8250	KIT 9 CLEANING ACCESSORIES	2	093055	107
M.4115	BLACK BRISTLE WHEEL BRUSH 21MM	5	090863	100	M.8270	KIT 58 CUTTING ACCESSORIES	2	093062	107
M.4120	3 ASSORTED BLACK BRISTLE BRUSH	5	090870	100	M.8500	MINI FLEXIBLE SHAFT 80CM	1	091426	108
M.4155	WHITE NYLON END WIRE BRUSH 5MM	5	090887	100	M.8550	KEYLESS CHUCK 0,4/3,2MM	1	091389	108
M.4160	WHITE NYLON CUP BRUSH 12MM	5	090894	100	M.8560	KEYLESS CHUCK 0,4/3,2MM DREMEL	1	093376	108
M.4165	WHITE NYLON WHEEL BRUSH 21MM	5	090900	100	M.8580	CHUCK WITH KEY 0,5/6MM	1	093598	108
M.4170	3 ASSORTED WHITE NYLON BRUSHES	5	090917	100	M.8600	ROTARY DRILL HOLDER 43+33MM	1	091433	109
M.4305	SILICON DISC POLISHER 12MM	5	090924	101	M.8710	MINI DRILL STAND	1	093666	109
M.4310	SILICON LENTICULAR POLISHER 12	5	090931	101	M.8750	MINI VICE 50MM	1	093383	109
M.4505	RUBBER POLISHING POINT 6MM	5	090948	101	M.8775	PRECISION SCREWDRIVER SET 45	1	093574	110
M.4510	RUBBER POLISHING POINT 5MM	5	090955	101	M.8790	PRECISION CUTTERS KIT 18 PCS	1	093581	110
M.4515	RUBBER POLISHING POINT 6MM	5	090962	101	M.8800	WOODBURNING PEN 30W + 2 TIPS	1	093550	110
M.4595	2 RUBBER POLISHING DISCS 22X3	5	090979	101	M.8815	GLUE GUN 30W - 7MM	1	093703	111
M.4605	FELT TAPER POLISHER 11MM	5	090986	102	M.8822	12 GLUE STICKS 7X100MM	10	600000	111
M.4610	FELT REV.TAPER POLISHER 14MM	5	090993	102	M.8845	GLUE GUN 60W - 11MM	1	093710	111
M.4615	FELT WHEEL POLISHER 22MM	5	091006	102	M.8857	12 GLUE STICKS 11X100MM	10	600208	111
M.4680	3 FELT POINTS + MANDREL +PASTE	5	091013	102	M.9000	ONE SPEED TRANSFORMER	1	091440	112
M.4810	COTTON YARN DISC 24MM	5	091020	102	M.9100	HIGH TORQUE ROTARY TOOL 30W	1	091464	114
M.4820	SOFT FELT WHEEL 21MM	5	091037	102	M.9150	MINI ROTARY TOOL KIT 30W	1	091471	114
M.4830	CHAMOIS LEATHER DISC 21MM	5	091044	102	M.9200	ENGRAVING PEN 6W	1	091488	112
M.4840	COTTON FOLDS DISC 21MM	5	091051	102	M.9220	ENGRAVING PEN 6W + TRANSFORMER	1	093628	113
M.4850	ABRASIVE DISC SCOTCH BRITE 22	5	091068	102	M.9250	ENGRAVING TOOL KIT 6W	1	091495	113
M.4905	UNIVERSAL PRE-POLISHING PASTE	5	091075	102	M.9500	HIGH TORQUE ROTARY TOOL 130W	1	093116	115
M.4910	PASTE FOR FINAL POLISHING	5	091082	102	M.9550	MINI ROTARY TOOL KIT 130W	1	093123	115
M.4915	LAPPING PASTE	5	091099	102	M.9600	HIGH TORQUE ROTARY TOOL 170W	1	093413	116
M.5010	5 SLIM CUT OFF DISCS 22X0,25MM	5	091105	103	M.9650	MINI ROTARY TOOL KIT 170W LCD	1	093420	116
M.5030	10 CUT OFF DISCS 22X0,6MM	5	091112	103	M.9700	HIGH TORQUE ROTARY TOOL 170W	1	093765	117
M.5035	50 CUT OFF DISCS 22X0,6MM	5	091129	103	M.9750	MINI ROTARY TOOL KIT 170W	1	093772	117
M.5040	10 REINFORCED CUT OFF DISCS 22	5	093680	103	M.BOX01	MODULAR STORAGE CASE	1	088228	106
M.5045	30 REINFORCED CUT OFF DISCS 22	5	093697	103	ESPO.M4A	PG MINI DISPLAYER 162 PCS	1	093789	118
M.5050	5 REINFORCED CUT OFF DISCS 40	5	091136	103	ESPO.M4C	PG MINI DISPLAYER 709 PCS	1	093802	118

## **GENERAL CONDITIONS OF SALE**

P.G. SRL DECLINES ALL RESPONSIBILITY FOR DAMAGES CAUSED BY ITS OWN PRODUCTS IMPUTABLE TO AN ERRONEOUS AND/OR INCAUTIOUS AND/OR IMPROPER USE OF THE SAME

Orders are accepted only at the following conditions:

- The transport is effected by the mean of conveyance considered more suitable by P.G. Srl
- Delivery leads are never binding and could be not respected, therefore compensations for delays and/or partial deliveries and/or non-deliveries are excluded
- Any complaint for objections or discrepancies found out on the materials delivered shall reach us within eight days from the receiving of the goods
- Payments shall be made according to the agreed conditions
- No price reduction or rounding off is accepted, unless previously agreed
- In case of late payment default interest and incidental charges shall run from due date
- Any dispute shall be settled by the Court of Bologna as the only Court of competent jurisdiction, though the contract has been entered in a different place

ANY USE AND/OR REPRODUCTION ALSO PARTIAL OF THE TEXT, OF DRAWINGS AND PICTURES IS FORBIDDEN IF NOT AUTHORIZED BY P.G. SRL

PICTURES, DESCRIPTIONS, DRAWINGS AND BOARDS ARE ONLY INDICATIVES AND NOT BINDING, P.G. SRL MAY CHANGE THE PRODUCTS WITHOUT ANY NOTICE



P.G. Srl  
Via Piretti, 12/A  
40012 Calderara di Reno (BO) Italia  
Tel. +39.051.727.102  
info@pgprofessional.it - info@pgmini.it



[www.pgprofessional.it](http://www.pgprofessional.it)  
[www.pgmini.it](http://www.pgmini.it)

